



MACRODYNE



Company Overview

Facilities & Engineering Capabilities..... 3

Press Frame Styles..... 7

Hydraulic Systems..... 13

Electrical Systems..... 15

Transportation & Logistics..... 17

Installation & Site Services..... 19

Parts & Service..... 21

Hydraulic Presses

Metalforming Presses..... 23

Press Lines & Automation..... 29

Hot Stamping Presses..... 33

Deep Draw Presses..... 35

Forging Presses..... 39

Cold Forming Presses..... 47

Extrusion Presses..... 51

Coining Presses..... 53

Hydroforming Presses..... 55

Die Spotting & Tryout Presses..... 59

Automotive Mold & Trim Presses..... 63

Super Plastic Forming Presses..... 67

Elastoforming Presses..... 69

Heated Platen Presses..... 73

Compression Molding Presses..... 79

RIM, SRIM and RTM Presses..... 83

Pulp Baling Presses..... 84

Research & Development Presses..... 85

Compaction Presses..... 89

Special Application Presses..... 91

Die & Mold Handling Equipment..... 95

Rolling Bolsters & Shuttles..... 99

Press Rebuilds & Upgrades..... 101

MACRODYNE TECHNOLOGIES INC.

HYDRAULIC PRESS & DIE HANDLING EXPERTISE



1600/900/500 ton double-acting draw press with hydraulic cushion

Over the last several decades Macrodyne has established a reputation for value in the supply of custom heavy duty hydraulic presses, press lines and die handling equipment. Our equipment is utilized in manufacturing operations for a broad range of industries including automotive, aerospace, industrial & consumer products, defense, construction, and many more.

Harnessing the power of the latest design tools including 3D modeling and finite element analysis, our dynamic and highly responsive team of engineers enables Macrodyne to offer the design, manufacturing and servicing of hydraulic presses up to 20,000 ton capacity, handling equipment for dies and molds weighing up to 100 tons, as well as the supply and integration of ancillary press line equipment.

Our extensive list of satisfied, repeat customers and strong growth is derived from our competitive advantage in price, quality, leading edge technology and after sales service.

Macrodyne hydraulic presses are available as stand-alone production equipment or can be integrated with virtually any productive ancillary equipment including press loading/unloading devices, transfer systems, robots, and fully automated die storage & retrieval systems. Turnkey supply is available for all Macrodyne equipment.

Our goal is to supply the highest quality equipment at competitive prices that will meet or exceed our customer's expectations. Please contact us any time to learn how Macrodyne hydraulic presses and die handling equipment can enhance your manufacturing operations.

LARGE CAPACITY FACILITIES

HEAVY HYDRAULIC PRESSES



Custom designed hydraulic press factory

Our facility was specially designed for the purpose of building heavy hydraulic presses and die handling equipment utilizing our high assembly bay, heavy lifting capacity, and large scale in-house machining capabilities.

We are strategically located in Concord, just north of Toronto, Canada. Our location is within 15 minutes of the Toronto Pearson International Airport. This provides our field service technicians with access to most of the central USA within an hour flight time. Major rail lines and highway access are also located nearby.



Large ram type boring mill

Several unique facility features include:

- Overhead crane lifting capacity in excess of 130 tons
- 35' clearance below the crane bridge
- Press assembly pit 30' x 20' x 15' deep, allowing for assembly of presses up to 50' tall
- Removable roof deck above pit to allow for assembly of presses greater than 50' tall
- Large ram type boring mill with X axis travel of 14,000 mm, Y axis travel of 4000 mm, and Z axis travel of 2500 mm
- 90 ton capacity CNC turntable for boring mill
- Separate fabrication bay with 35 ton lifting capacity

ENGINEERING CAPABILITIES

HYDRAULIC PRESS DESIGN EXPERTISE



20,000 ton high pressure framing press system

Macrodyne's expert staff of mechanical, hydraulic, electrical and control engineers have decades of practical design and field experience. Our assembly and field service teams complement our engineering group to provide customers with comprehensive expertise and support throughout all phases of the project.

Our extensive portfolio of custom hydraulic press and die handling equipment designs have been developed with the versatility and flexibility necessary for a wide variety of production demands.

Up time, serviceability and reliability are paramount features in today's highly demanding manufacturing environments.

All Macrodyne hydraulic presses and die handling equipment are designed with these criteria in mind.

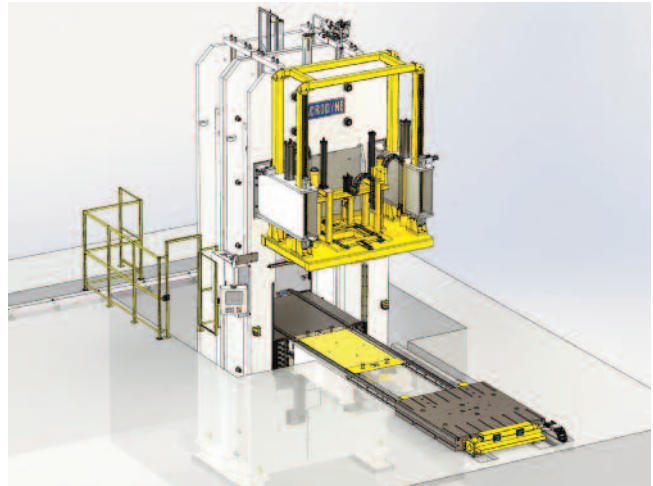

5000/2000 ton rubber transfer molding press with shuttle table

All mechanical, hydraulic and electrical systems for Macrodyne equipment are designed in-house. This ensures we maintain a high level of internal expertise necessary to offer industry leading products and after sales support.

Macrodyne is committed to an innovative approach to technological improvements ensuring the highest levels of equipment quality and value.

Our engineering capabilities include:

- Complete mechanical design utilizing AutoCAD, SolidWorks 3D modeling, and finite element analysis
- Complete hydraulic design
- Complete electrical design, programming and configuration

PRESS FRAME STYLES

FRAME TYPES TO SUIT ANY APPLICATIONS



Variety of presses with different frame styles shown during assembly in our factory

PRE-STRESSED HOUSING PRESSES

Macrodyne's pre-stressed housing style press frames are comprised of separate structural components including the bed (also referred to as the base or bottom platen), crosshead, housings, tie rods, as well as regular and pre-stressing tie rod nuts.

Cyclical loading of the press frame due to operation of the press can result in metal fatigue. By incorporating a pre-stressed tie rod arrangement in our housing frame presses, the risk of metal fatigue is greatly reduced, resulting in extended service life of the press.

This frame style is suitable for presses where the frame is too heavy to be shipped as a single piece.



2000/400 ton single-acting pre-stressed housing style draw press with hydraulic cushion and rolling bolster

PRESS FRAME STYLES

MONOLITHIC PRESSES



660 ton metalforming press with monolithic frame design

Macrodyne's monolithic frame style presses are a popular choice with our customers as they simplify installation and are more cost effective than housing frame style presses of the same size.

They are a viable option when the frame is small enough to be shipped as a single piece. A monolithic style press frame is a single unitized weldment that is thermally stress relieved prior to finish machining.



500 ton metalforming press with monolithic frame design

This frame style is very rigid and torsion resistant, promoting enhanced off-center loading capability.

Like all Macrodyne hydraulic presses, our monolithic frame style press designs are optimized through finite element analysis (FEA) to ensure they can accommodate the deflection and stresses generated during the pressing application.

MULTI-FRAME PRESSES



1500 ton hydroforming press with multi-frame design

Multi-frame style presses are typically used for very high tonnage presses. The structural elements are modular which allows for ease of handling, rigging, and transportation, as they consist of multiple frame structures. Another key benefit of this frame style is uniform as opposed to concentrated force distribution over the frame members, creating a more efficient structure.

A multi-frame style press is comprised of multiple thermally stress relieved heavy welded frames, pre-stressed together with tie rods and pre-stressing nuts.

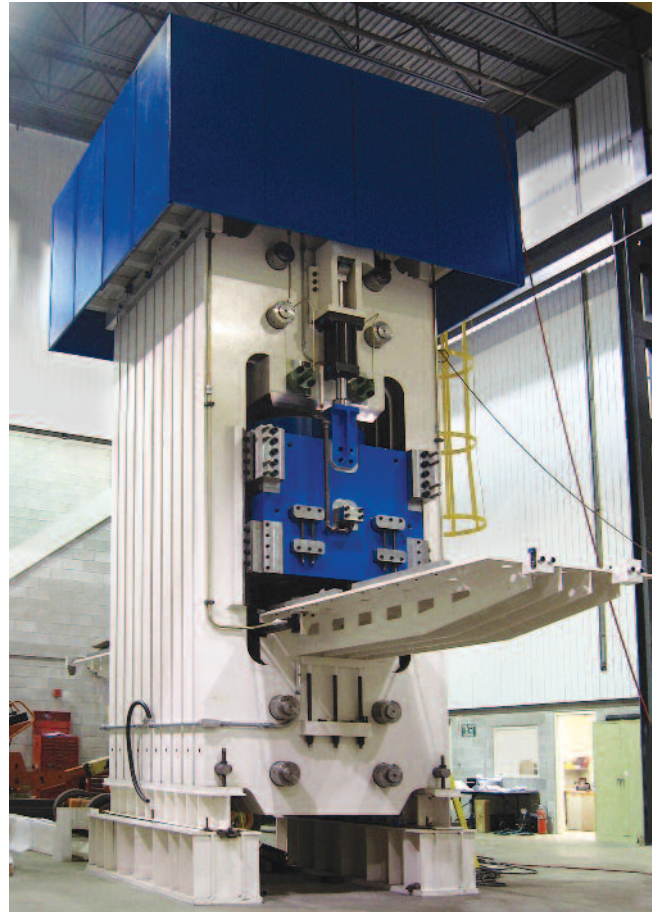

11,000 ton elastoforming press with multi-frame design

The frame structures are designed using 3D CAD models and finite element analysis (FEA) to ensure proper deflection and stress criterion are met.

The frame elements are mounted on two (2) foundation beams that are machined to provide accurate positioning of the frames. This ensures that the supporting surfaces of the upper bolster and cylinders base are co-planar, resulting in equal distribution of loads to each of the frames.

PRESS FRAME STYLES

4-COLUMN PRESSES



200 ton 4-column press



50 ton 4-column press



80 ton 4-column press

Macrodyne 4-column type presses are designed for the high speed production of a wide variety of complex, precise parts.

Macrodyne 4-column presses feature deep slides offering precision guiding and parallel slide motion.

Our 4-column press frame design provides greater access to all four sides of the die area for automation, die change, and part loading and unloading.

Macrodyne 4-column type presses are available with a wide variety of options:

- Single or multi-point cushions
- Shock dampening packages
- Parallel leveling packages
- Quick die change packages
- Integration of automation
- Enhanced press control packages
- Point of operation protection (light curtains, etc)

GAP FRAME PRESSES



100 ton gap frame press

Macrodyne gap frame presses can be supplied with either gib or plunger type guiding which offers enhanced parallel slide motion and eccentric load capabilities.

Macrodyne gap frame presses are economical and are ideal for applications where access is required from three sides.



Two (2) 200 ton gap frame presses

Macrodyne gap frame presses are available with a variety of options including:

- Single or multi point cushions
- Open back configurations
- Rotary tables
- Part ejector arrangements
- Quick die change packages
- Other enhancements as offered with 4-column presses

MACRODYNE HYDRAULIC SYSTEMS

EXTENSIVE OPERATIONAL FLEXIBILITY

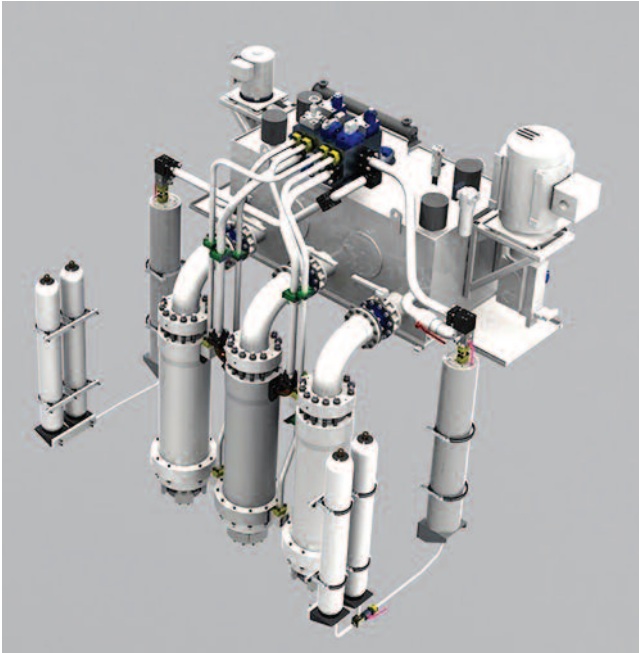

Layout of hydraulic power unit with an accumulator drive

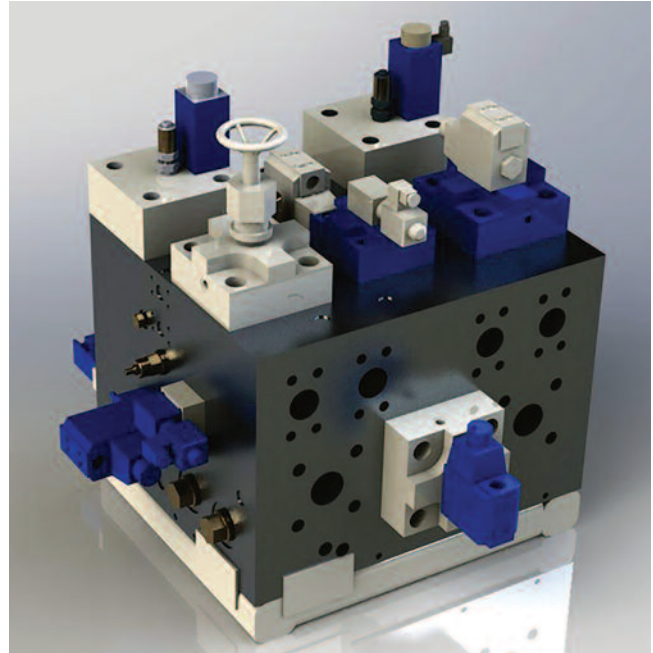

Custom control manifold

Macrodyne hydraulic systems are on the forefront of technological advancement and incorporate the latest state-of-the-art hydraulic components including pressure compensated axial piston pumps with electronic pump control, extreme high pressure piston pumps, and proportional or servo controlled valves. Valves are mounted to manifold blocks to wherever possible, minimizing potential leakage points.

When controlled by Macrodyne's advanced electrical control systems, our hydraulic systems offer extensive operational flexibility and functionality. High system performance and reliability is achieved through incorporation of separate kidney loop circuits for filtration and cooling.

Hydraulic systems are designed to ensure maximum accessibility and ease of maintenance. Our hydraulic systems utilize commercially available components from industry leading hydraulic component manufacturers. This ensures the highest hydraulic system quality and worldwide availability of replacement parts.

Macrodyne hydraulic systems can be mounted on top of the press, on the floor, in a pit, or in virtually any configuration necessary to meet the Buyer's specific requirements.

Macrodyne hydraulic systems have many available advanced features including:

- High efficiency systems using variable speed motors and variable flow pumps resulting in significant reductions in power consumption compared to traditional pump/motor groups by matching energy consumption to energy demand
- High position accuracy using high speed, closed loop servo-proportional valves
- Extremely accurate pressure control with closed loop pressure controllers for pressure increase, holding and decompression through use of a position controlled intensifier
- Accumulator drive systems to reduce horse power peaks and increase production rates
- Extremely slow pressing speeds using digital valves to control minute oil flows
- Individual accumulators at each valve to provide instantaneous response for any oil demand which increases overall system performance
- Safety vent option to protect system during product blow out
- Additional system monitoring for ease of troubleshooting
- Separate vane pump for oil cooling and filtration
- Fluid condition monitoring for preventative and predictive maintenance



Hydraulic system for a 1000 ton hot stamping press featuring non-welded piping



Hydraulic units for a Macrodyne tandem press line on a common platform

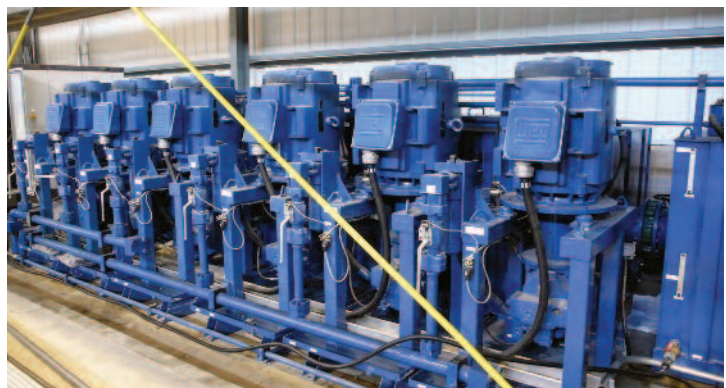

Six (6) pump/motor groups w/pressure compensated piston pump and 250 HP motor

ELECTRICAL & CONTROL SYSTEMS

FUNCTIONALITY, SIMPLICITY & FLEXIBILITY



Macrodyne electrical control packages offer a wide range of process specific functionality and capability. All necessary functions for operation of the press and ancillary equipment are provided on a color, graphic based interface or an ergonomically designed manual control package. Fully customizable menu type configuration ensures simple, flexible, user-friendly operation without the need for special technical expertise.

Control systems range from a basic manual package to a high level computer based system with integration of sub-systems for ancillary equipment packages, in-plant production monitoring and data acquisition systems.

We have extensive experience with both Allen Bradley and Siemens hardware platforms and can custom design an innovative control system solution tailored to your specific application requirements.

Functionality, simplicity and flexibility are paramount design criteria for all Macrodyne electrical control systems which are custom designed for your application.

To simplify operator training and use, the controls and operator interface screens can be designed to match existing presses.

Enhanced control options include:

- Equipment operating parameter settings
- Production data acquisition and process monitoring
- Part and batch counters
- Extensive fault diagnostics capabilities
- Tooling data and set-up storage capability
- Preventative and routine maintenance screens
- NC functionality
- Integration with ancillary sub systems
- Integration of safety sub systems
- Data acquisition package
- Remote diagnostics

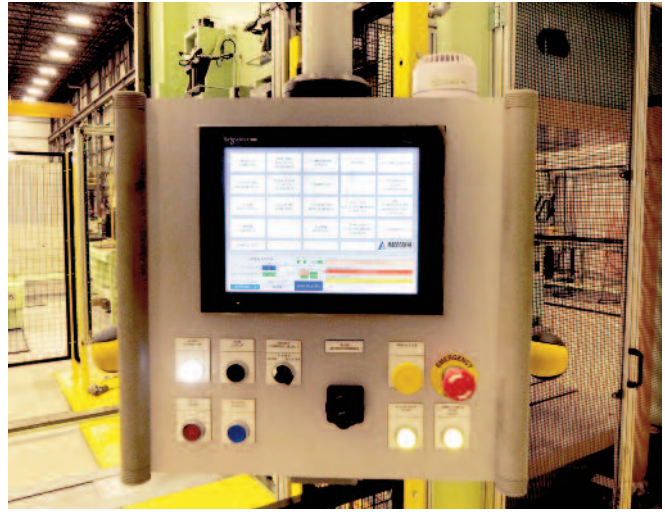

TRANSPORTATION & LOGISTICS

EXPERTISE SHIPPING LARGE EQUIPMENT





At Macrodyne, we have extensive experience shipping very large hydraulic presses. All of our equipment is designed with transportation requirements in mind.

Regardless of how big or small the press, we can arrange door to door delivery to any location worldwide, quickly and economically.

With single components weighing in at over 100 tons, expertise in transporting heavy equipment is a critical component of our success.



Macrodyne maintains strategic long standing relationships with highly capable trucking companies, heavy haul carriers, rail carriers, and international logistics companies specializing in rail and ocean freight.

From loading equipment on Buyer supplied trucks to complete turnkey delivery, we have the flexibility and expertise to ensure our presses reach their destination on time, in pristine condition.

INSTALLATION & SITE SERVICES

BIG OR SMALL WE INSTALL



With Macrodyne installation and site services, your equipment will be installed in the most efficient manner possible with minimal impact to your existing manufacturing operations. Macrodyne offers a complete range of installation services for all the equipment that we manufacture.

Whether you require a complete turnkey supply or only installation supervision for your own personnel and contractors, we can provide you with a solution that meets your schedule and budget.



Macrodyne manufactures heavy presses that often require the plant to be built around the press or press line itself.

Our expertise in coordinating all the various contractors minimizes the overall time and cost required to complete the installation and building construction.



Drawing on our experience from the successful installation of many large complex hydraulic presses, press lines and die handling systems, the safety of personnel is given the highest priority at every step of the installation process, while ensuring no damage occurs to the machinery or facilities.

No installation is complete until the press is entirely production ready and all the operators and maintenance staff have been fully trained on the specific equipment supplied.



Macrodyne installation and site services include start-up and commissioning, training, and site acceptance testing.

Optional production support and monitoring from our controls experts is readily available to aid in the transition from operational trials to full production.

AFTER SALES SUPPORT

READILY AVAILABLE ON DEMAND ASSISTANCE



FIELD SERVICE & SUPPORT

Macrodyne takes pride in offering our customers engineering and after sales services that support productive manufacturing. Our engineering groups complement our field service teams throughout the extensive operating life of the equipment. Electrical control systems and hydraulic power units are designed and built in-house to maintain maximum know-how with the equipment and access to knowledgeable staff.

We offer a complete range of services including:

- Cost effective preventative maintenance programs
- Remote diagnostic services
- Customized operator & maintenance personnel training
- Troubleshooting services
- Operation & maintenance manuals
- System integration services for ancillary equipment
- Repair and rebuild services for all makes of hydraulic presses

SPARE & REPLACEMENT PARTS

Macrodyne has long established relationships with industry leading manufacturers of hydraulic components and electrical system components including Allen Bradley, Siemens, Bosch Rexroth, Vickers, Parker, Oilgear, and more.

This enables us to offer comprehensive spare parts packages for our equipment and ensures we have an established connection with the manufacturer when replacement parts are needed in emergency situations.

The comprehensive documentation package provided with all our manufactured equipment includes detailed spare parts lists. These lists include an itemized risk analysis indicating the importance of the recommended part and the approximate lead time of each item.

Macrodyne also offers custom replacement parts for presses from other manufacturers including major press structures and cylinders in addition to commercially available components.

METALFORMING PRESSES



Three (3) 200 ton metalforming presses with two (2) 220/100 ton single-acting draw presses with hydraulic cushions

Macrodyne hydraulic metalforming presses are designed for a wide variety of parts production, from large body panels and structural components to small individual parts.

These presses are available in all frame styles (monolithic gib guided, 4-column, gap or “C” frame, pre-stressed housing style and multi-frame). Macrodyne can recommend the optimal frame style based on the specific application requirements, or the Buyer can select their preferred style.

Regardless of the frame style selected, all structural components for our press frames are stress relieved, designed with 3D Solid Works, and optimised by finite element analysis. This ensures our presses are built to accommodate the required deflections and stresses seen during the pressing cycle. Replaceable hardened liners are provided for the guiding surfaces of the press frame.



400 ton metalforming press



300 ton metalforming press



800 ton metalforming press

Macrodyne provides single, double, or triple action hydraulic press based solutions for a wide variety of metalforming processes that include the following:

- Deep draw applications
- Transfer applications
- Super plastic forming
- Die spotting & try-out
- Hydroforming
- Cold forming
- Forging
- Cutting
- Hot stamping
- Coining
- Straightening
- Embossing
- Trimming
- Elastoforming
- Blanking
- Fine blanking
- Bending
- Piercing
- Extrusion

METALFORMING PRESSES



Two (2) 400 ton metalforming presses

Macrodyne hydraulic metalforming presses are designed and manufactured to have the reliability, versatility and flexibility necessary for a wide range of complex metalforming processes.

Our metalforming presses can be supplied as standalone equipment or as part of a fully automated press line or cell. We can supply the entire press line or cell on a turnkey basis, provide system integration services for Buyer-supplied automation and ancillary equipment, or simply provide a provision in the press controls to communicate with automation and other ancillary equipment.



Two (2) 400 ton door embossing presses with quick die change systems

Macrodyne's extensive experience in the supply of automated systems enables us to work closely with the end user to develop a customized approach, providing any level of involvement in the system integration as desired by the Buyer.

This ensures a solution that is optimized for your specific production requirements while working within your budget.

Macrodyne hydraulic metalforming presses are available with an extensive list of optional equipment including: single and multi-point cushions, automatic centralized grease lubrication systems, single and multiple position slide locking arrangements, manual and automatic die clamping packages, work area LED lighting, remote diagnostics packages, data acquisition systems, and many more.

For metalforming applications such as punching, blanking, or trimming metal parts where excessive reverse forces are generated at the moment of part breakthrough, Macrodyne hydraulic metalforming presses can be supplied with a blanking damper arrangement.

These arrangements drastically reduce the shock to the tooling, press structure, and hydraulic system. This also allows for faster cycle times while accommodating off center loads, and reducing vibration and noise at the operator level.

If breakthrough forces are not a concern at the time of purchase but may be in the future, Macrodyne can design the press with a provision to accept a blanking damper arrangement in the future.



1500 ton metalforming press for the production of motorcycle parts

METALFORMING PRESSES



1200 ton metalforming press

Macrodyne hydraulic metalforming presses feature deep, heavy fabricated slides. This results in precision guiding, parallel slide motion, and enhanced eccentric load capacity.

These presses can be supplied with standard or custom T-Slot configurations in all sizes, and/or a tapped hole pattern to meet the Buyer's tooling requirements.

Operator safety is a critical design consideration. Our metalforming presses are designed to comply with applicable safety standards and regulations including: ANSI, OSHA, CSA, CE, etc.

A full range of point-of-operation protection is available for all our presses including: safety gates & fencing, operator pedestal stations, light curtain arrangements, laser scanners, die block arrangements, and more.

Macrodyne offers a variety of innovative solutions including a low headroom design. Where facility height restrictions are an issue, the hydraulic power unit can be mounted on the backside of the press.

This results in a reduction of the overall height while eliminating the need for a shallow pit or floor mounted hydraulics, which consume additional floor space.

Macrodyne also offers a line of die handling equipment to serve our hydraulic metalforming presses. This equipment ranges from simple manual die carts to fully automated die storage & retrieval systems. Please refer to the Die Handling Equipment section of this brochure for more information.



400 ton metalforming press featuring low headroom design

PRESS LINES & AUTOMATION



Press line for automotive body panels comprising of one (1) 2500 ton double-acting draw press with 500 ton NC cushion, four (4) 1250 ton single-acting presses, and six (6) robots for press loading, unloading and press-to-press transfer. Each press is equipped with two (2) 180" x 96" rolling bolsters in a "T" type configuration

Macrodyne manufactures hydraulic press lines and automated manufacturing cells for a multitude of production applications. Our press lines and automated cells can be supplied with high speed press-to-press transfer systems or robots, to offer rapid, flexible and efficient production for high volume or just-in time demands.



Macrodyne tandem press line for air conditioner panels comprising of one (1) 550/150 ton draw press, one (1) 200 ton press, two (2) 150 ton presses, destacker, five (5) feeders, exit conveyor, and fully integrated Macrodyne die storage & retrieval system

Our press lines are also available with a full contingent of Macrodyne die storage and retrieval systems. These fully automated systems can reduce full line part changeovers from several hours to only a few minutes. This results in significant reduction in downtime during part changeovers. For more details on Macrodyne's die handling equipment, please visit our website or contact us directly at sales@macrodynepress.com or by telephone at (905) 669-2253.

PRESS LINES & AUTOMATION



1350 ton hot stamping press line

Macrodyne can supply and/or integrate a wide variety of ancillary equipment with our hydraulic presses including:

- Blank destacking systems
- Coil feed systems
- Conveyors
- Shuttle tables
- Rolling bolster arrangements
- Die handling equipment
- Automated die storage & retrieval systems
- In-press and press-to-press transfer systems
- Robotic loading & unloading arrangements
- Ovens and furnaces
- Scrap conveyors and chutes
- Vacuum handlers



Hydraulic press line for automotive heat shields

Six (6) independent Macrodyne hydraulic, gib guided straight side presses are at the heart of this hydraulic press line which is used for the manufacture of automotive heat shields. Line automation includes (3) servo coil feeders, (2) robots, servo transfer system, (6) scrap conveyors, die lubrication system, part vision system, and a powered quick die change system. This line produces a part every 6 seconds and a complete line changeover can be accomplished within 1 hour.



300 ton press cell for automotive sunroofs

This Macrodyne hydraulic press cell for the production of automotive sunroofs includes (2) Macrodyne 300 ton presses, (2) robots for part loading & unloading, and a Macrodyne die storage & retrieval system. Each press is equipped with a hydraulic blanking package, and automatic die clamping & lifting package. The Macrodyne die storage & retrieval system consists of (2) double die cart assemblies (each with dual push-pull devices, support & guiding rollers, and die plate latching assemblies), associated actuating devices, die plate assemblies, and rail systems.

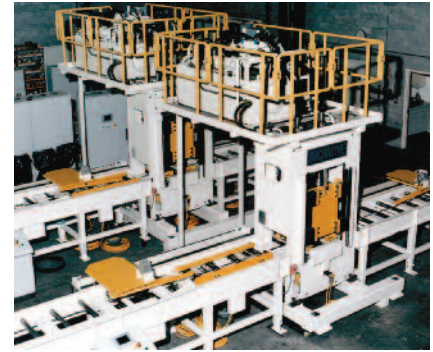

Two (2) 250 ton press lines for plow blades

Each of the two hydraulic press lines shown above consist of (1) Macrodyne 250 ton press, (1) feed system loading arrangement, and (1) feed system unloading arrangement. Each press features a part hold down device, (2) programmable aligning devices, slug chute, and scrap conveyor. The loading arrangement includes powered and idler roller sections, end stop, tilt assembly, programmable indexing carriage assembly, and (2) programmable aligning devices. The unloading arrangement includes powered and idler roller sections, and a programmable indexing carriage assembly.

HOT STAMPING PRESSES



1000 ton hot stamping press line

Macrodyne hot stamping presses provide the ability to produce a variety of higher strength and lighter weight automotive parts with complex geometries such as door beams, roof rails, body pillars, bumpers, tunnel reinforcements, and more.

The use of hot stamping technology (also referred to as press hardening) to produce structural vehicle components is a key initiative in improving automotive fuel efficiency, resulting in the production of higher strength and lighter weight components. Hot stamping involves rapid quenching of boron steels heated above 900 degrees Celsius.

The hot stamping process involves destacking a blank and loading it into an oven or furnace to be heated. Once heated, the blank is then transferred to a hot stamping press, which then must close and generate tonnage very quickly before the blank cools, after which it is automatically unloaded from the press.

There are several key variables to consider when purchasing a hydraulic hot stamping press or hot stamping press line. Macrodyne has extensive experience in hot stamping and will work closely with you to ensure all aspects are considered.

The hydraulic and control systems for a hydraulic hot stamping press must be capable of fully programmable and repeatable tonnage control.

Press frame style, guiding systems, speeds, tonnage, material feed direction, quick die change and off-center loading capability must all be carefully evaluated to ensure that the press will be optimized for your specific hot stamping application.

Macrodyne hot stamping presses are available as standalone equipment integrated with customer supplied ancillary equipment or can be supplied as complete turnkey press lines with a variety of optional items including:

- Single or dual rolling bolsters
- Robots or feeders for part loading/unloading
- Blank destackers
- Roller hearth or stack ovens
- Tooling
- Part conveying systems
- Data acquisition systems
- Remote diagnostics packages
- Press line safety systems

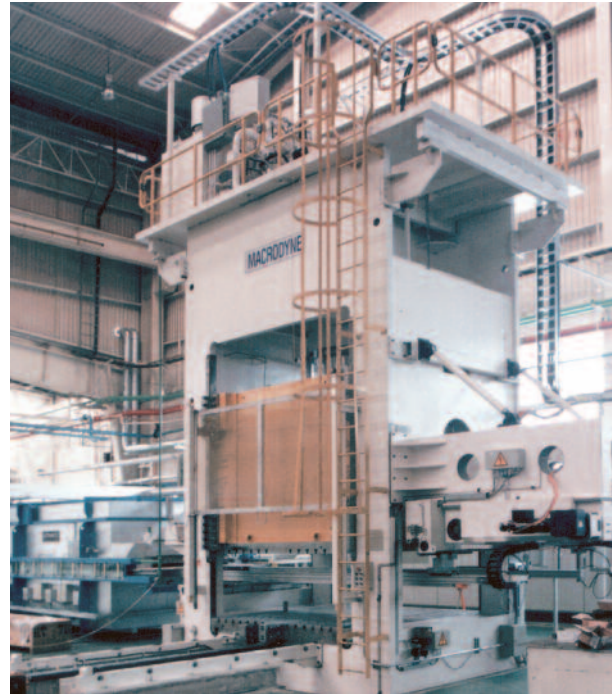

1100 ton hot stamping press line



660/220 ton dual capability hot stamping/deep draw press

DEEP DRAW PRESSES



1100/200 ton single-acting deep draw press with hydraulic cushion and rolling bolster

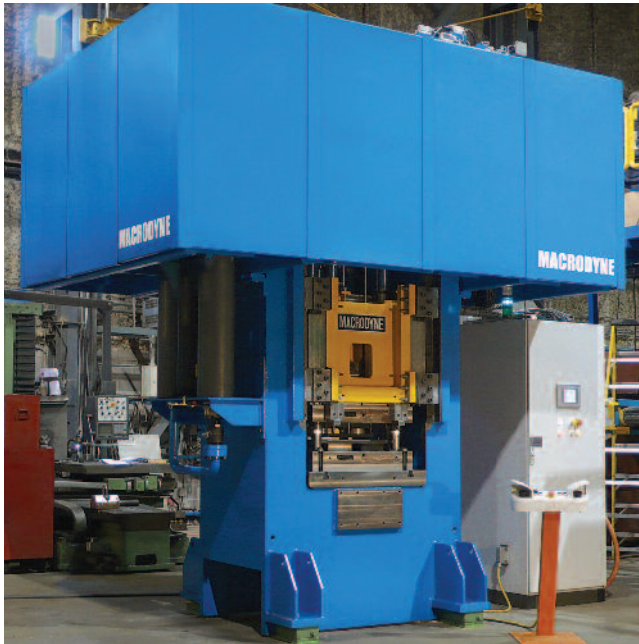

100/150 ton high speed double-acting draw press

Macrodyne hydraulic deep draw presses provide the ability to rapidly and cost effectively manufacture high precision deep drawn components for a variety of industries including automotive, appliance, cookware, medical, consumer & industrial products, and more.

The repeatable and precise performance of our hydraulic deep draw presses offers the optimal process control required to form a wide array of parts reliably. Macrodyne deep draw presses are used to produce parts from various materials such as aluminum, low carbon steel, stainless steel, copper, brass, and others.

Examples of parts produced on Macrodyne deep draw presses are as follows:

- Automotive (body components, oil pans, gas tanks etc.)
- Appliance (panels for washer/dryer, fridge, stove, etc.)
- Cookware (pots, pans, etc.)
- Industrial/consumer products (fan hoods, air conditioner panels, light fixtures, sinks, electrical fixtures, etc.)



2000 ton single-acting draw press with hydraulic cushion & rolling bolster

There are numerous advantages to using the deep draw process to produce certain metal parts compared to traditional molding or casting. Macrodyne deep draw presses provide optimal control of force distribution and material flow, resulting in structurally superior finished parts while eliminating wrinkling or tearing of the material.

Deep drawing reduces waste and minimizes production costs as the process results in the manufacture of a net shape using minimal material. Assembly costs can also be reduced by redesigning multiple components into one deep drawn part.

DEEP DRAW PRESSES



1600/900/500 ton double-acting deep draw press with hydraulic cushion and two (2) 180" x 96" rolling bolsters



200/100/50 ton double-acting draw press with hydraulic cushion

Macrodyne deep draw presses can be supplied in several configurations; single-action, single-action with cushion, double action, double-action with cushion, or triple-action.

These presses are available as standalone equipment or can be supplied complete with a wide variety of ancillary equipment including robots, coil feed systems, destackers, transfer systems, scrap conveyors, automated die storage & retrieval systems, and more.



1200/4 x 200 ton single acting deep draw press with hydraulic cushion

In addition to the multitude of options available on all Macrodyne hydraulic presses, the following options are available for our deep draw presses including:

- Passive, active and multi-point cushions
- Multi-point blank holders
- Die clamping & lifting packages
- Parallel leveling packages
- Stroke limiting and shock dampening packages

FORGING PRESSES



5500 ton ring blank forging press

Macrodyne hydraulic forging presses are designed for the production of a wide variety of forged products including gears, flanges, bearings, wheels, shafts, axles, and other heavy industrial components.

Macrodyne hydraulic forging presses are specially designed for a range of processes including:

- Upsetting
- Extrusion
- Trimming
- Piercing
- Coining
- Open die forging
- Closed die forging
- Ring blank forging

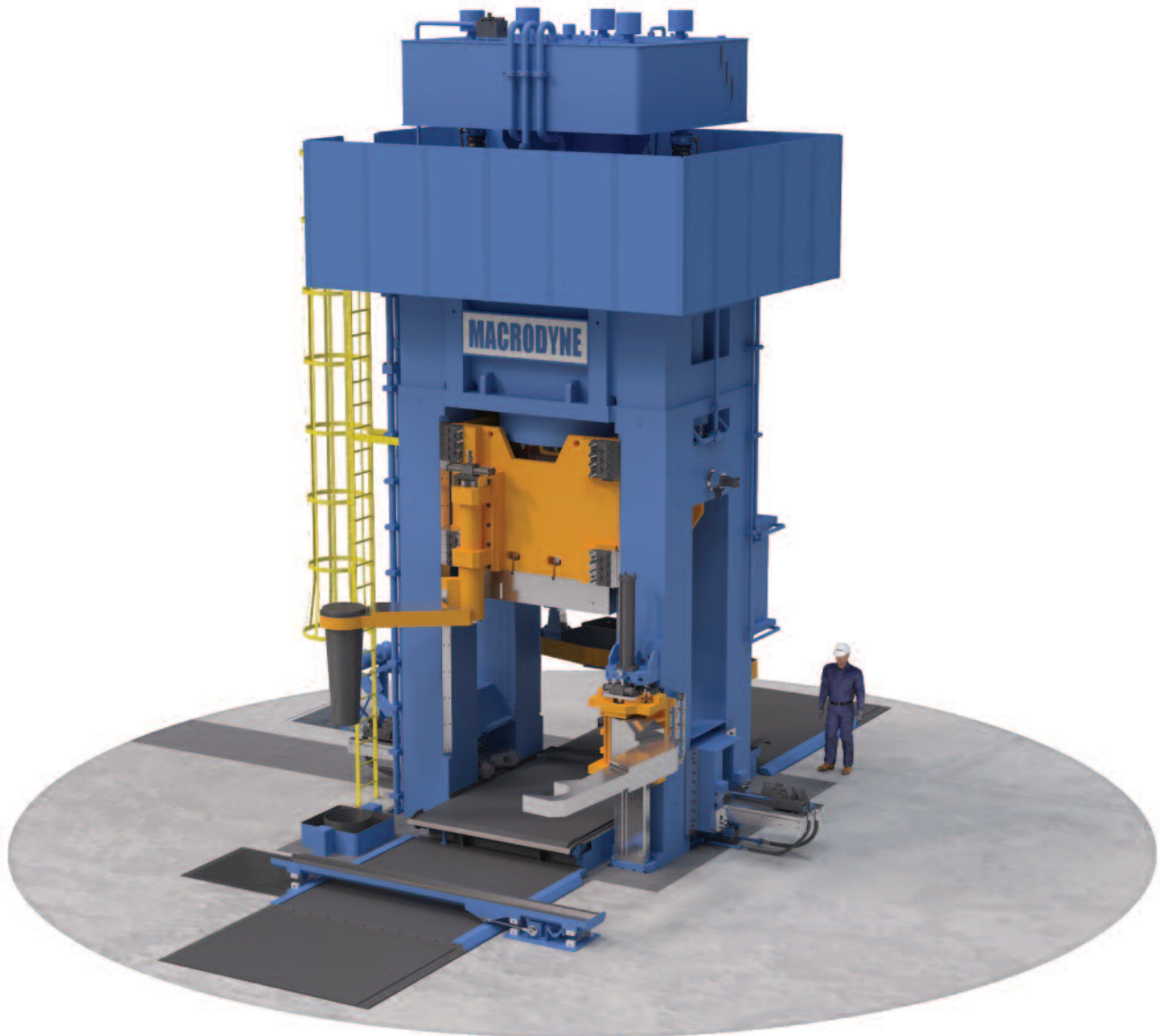

This 5500 ton hydraulic ring blank forging press with closed loop motion control is equipped with the following features:

- 3 position sliding bolster assembly
- Pre-pierce assembly
- Hold down arm assembly
- Pierce cylinder arrangement
- Ring blank centering & lifting arrangement
- Slug pusher & conveyor

FORGING PRESSES

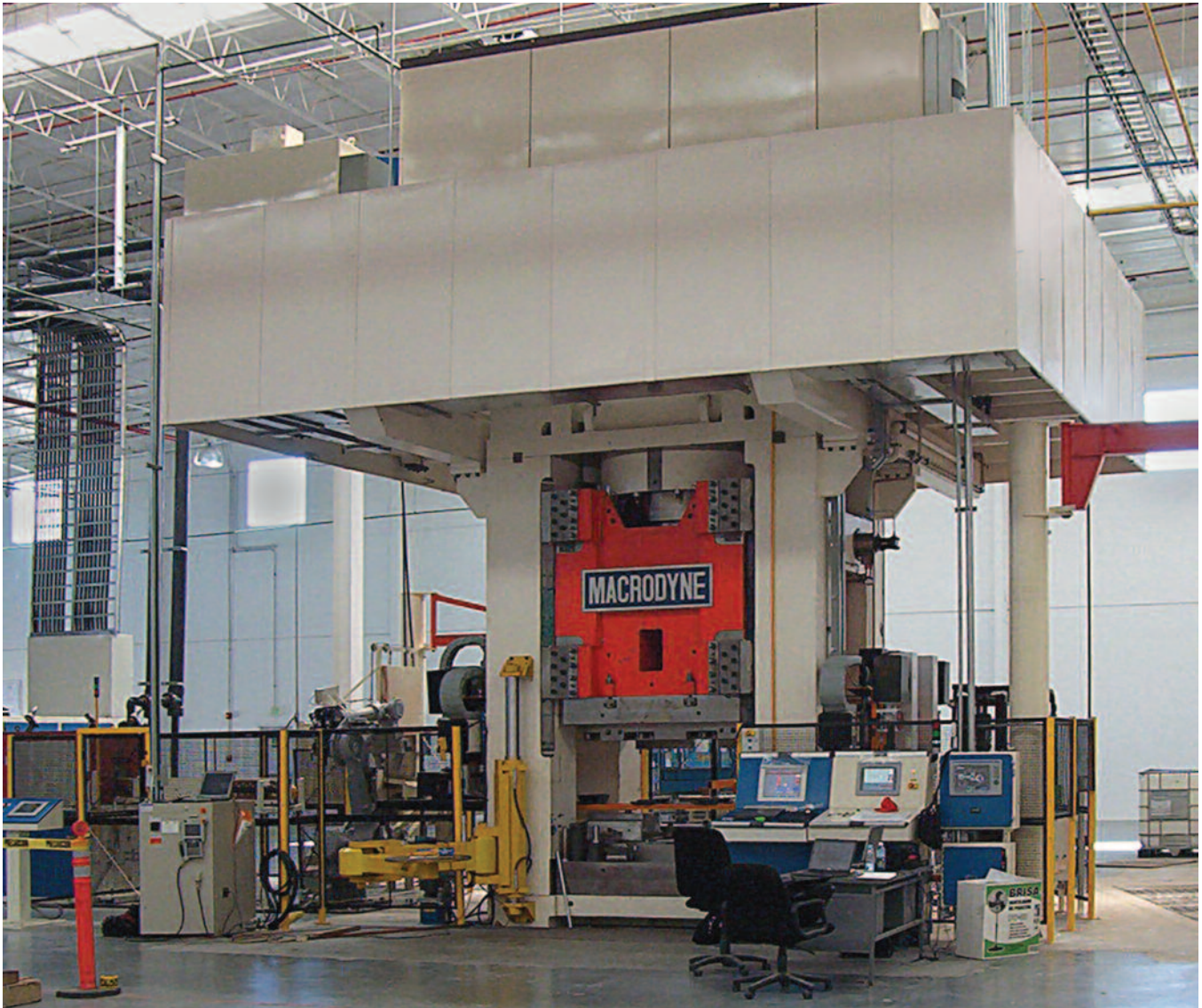

4000 ton ring blank forging press

Available in capacities up to 20,000 tons, Macrodyne forging presses provide precise, high speed performance, offering the optimal press control necessary to produce a wide array of open or closed die forged products for industrial, automotive and aerospace applications.

Macrodyne's forging presses have deep slides with adjustable precision guiding to accommodate heavy offset loading. Our forging presses can be supplied in either two or 4-column style, in top-drive or under-drive configurations. Hydraulic systems can be either oil or water based.

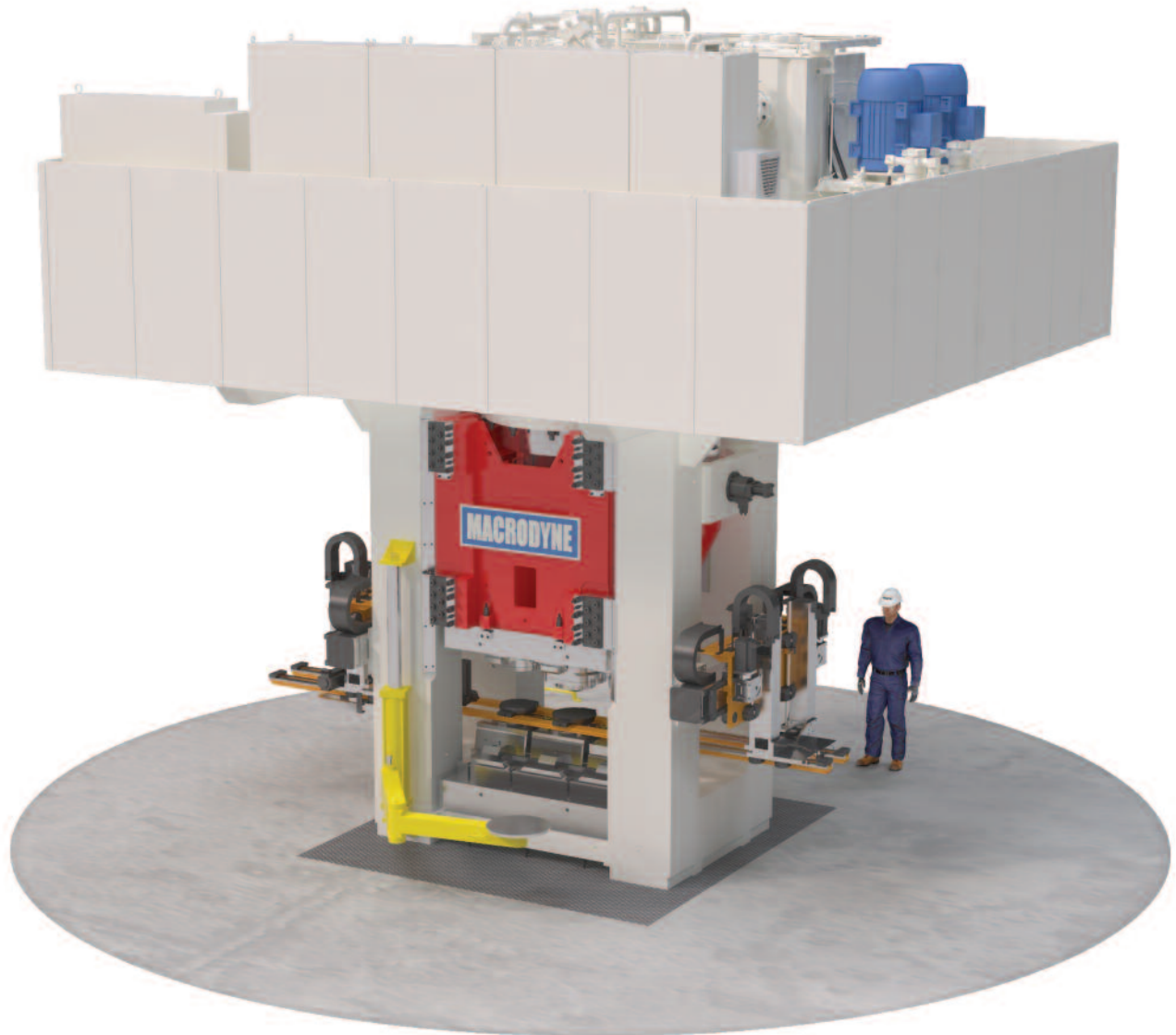

4000 ton ring blank forging press has 3 stations (upsetting/indenting/piercing) and is equipped with the following items:

- 1000 HP hydraulic drive
- 3-station in-press transfer system
- Billet loading robot
- Induction furnace
- Unloading conveyor
- Hydraulic tool change arm
- Three (3) lower ejector assemblies
- Three (3) upper ejector assemblies

FORGING PRESSES



400/400 ton closed die forging press

The above 400/400 ton closed die forging press was specially designed for the production of hydraulic tube fittings. It features an 800 ton frame and a heavy-duty hold down slide. A custom cylinder arrangement was included comprising a 400 ton main cylinder with integral high speed cylinder and four (4) 100 ton die hold down cylinders. A part chute complete with a reject system for nonconforming parts was also provided.



800 ton calibration press

The above 800 ton press was supplied for the calibration of heavy duty flanges for oil & gas pipe lines. This press features a deep heavy fabricated slide and a solid steel bolster plate, both of which are equipped with flat machined working surfaces to facilitate calibration operations within the press. A mobile remote press operation control with open & close pushbuttons and E-stop was provided to allow an operator to operate the press remotely after loading a flange into the press for calibration.



1000 ton forging press

The above 1000 ton forging press was specially designed for the production of titanium bolts and nuts for submarines. The press features closed loop speed and pressure control. A number of custom features were provided with the press including hydraulic ejectors, knock-out arrangement, die shuttle, die knock out press, and quick die change package.



2000 ton open die forging press

The above 2000 ton forging press is used for the production of forged tantalum parts. The press was supplied with an application specific control system with many features including proportional pressure and speed control, ejector functions, slide position control & monitoring, fault logging & diagnostics, and a variety of other useful functions. Interface with a manipulator was also included.

FORGING PRESSES



1100 ton forging press line

Macrodyne forging presses can be supplied as standalone equipment or as fully automated forging press lines. These forging press lines can be supplied turnkey or we can provide system integration services for customer supplied ancillary equipment. We can tailor an optimal solution to meet your specific application and budget requirements.

Macrodyne hydraulic forging presses are available with a variety of ancillary equipment including:

- Automatic die storage & retrieval systems
- Transfer systems and part loading robots
- Automatic clamping systems
- Conveyor systems
- Manipulators
- Induction furnaces
- Sliding tables
- Rotary tables



This forging press was designed for the production of axle spindles for heavy trucks and includes the following items:

- 1100 ton 4-station forging press
- 1100 ton 2-station forging press
- Induction furnace
- Three (3) Robots
- Scrap conveyors
- Fire detection package
- Part temperature control package
- Die and bed plate change system

COLD FORMING PRESSES



2000 ton cold forming press line

Macrodyne manufactures hydraulic cold forming presses and cold forming press lines for the production of a variety of components such as ferrules and stems for heavy duty hydraulic hose fittings. These presses are typically supplied in the monolithic frame, down-stroking configuration with side openings to accommodate automatic loading/unloading, and in-press transfer systems where required.

Our cold forming presses are used to form a multitude of products using metal blanks or slugs that are inserted into the press at ambient temperatures. By forming the material "cold", the additional cost and time associated with pre-heating of the material prior to entering the press is eliminated. Accordingly, these presses are an optimal solution for high volume production, particularly when supplied as fully automated cold forming press lines with integrated automated loading/unloading systems.



This 2000 ton hydraulic cold forming press line was supplied to a manufacturer of heavy construction equipment for the production of high pressure hydraulic hose fittings and is equipped with the following:

- 2000 ton cold forming press with closed loop strippers and ejectors
- 5-station in-press servo controlled transfer system
- Automated die storage & retrieval system
- Hydraulic clamping & lifting package
- Hydraulic tool change arm
- Hopper feeder
- Automatic grease lubrication system

COLD FORMING PRESSES

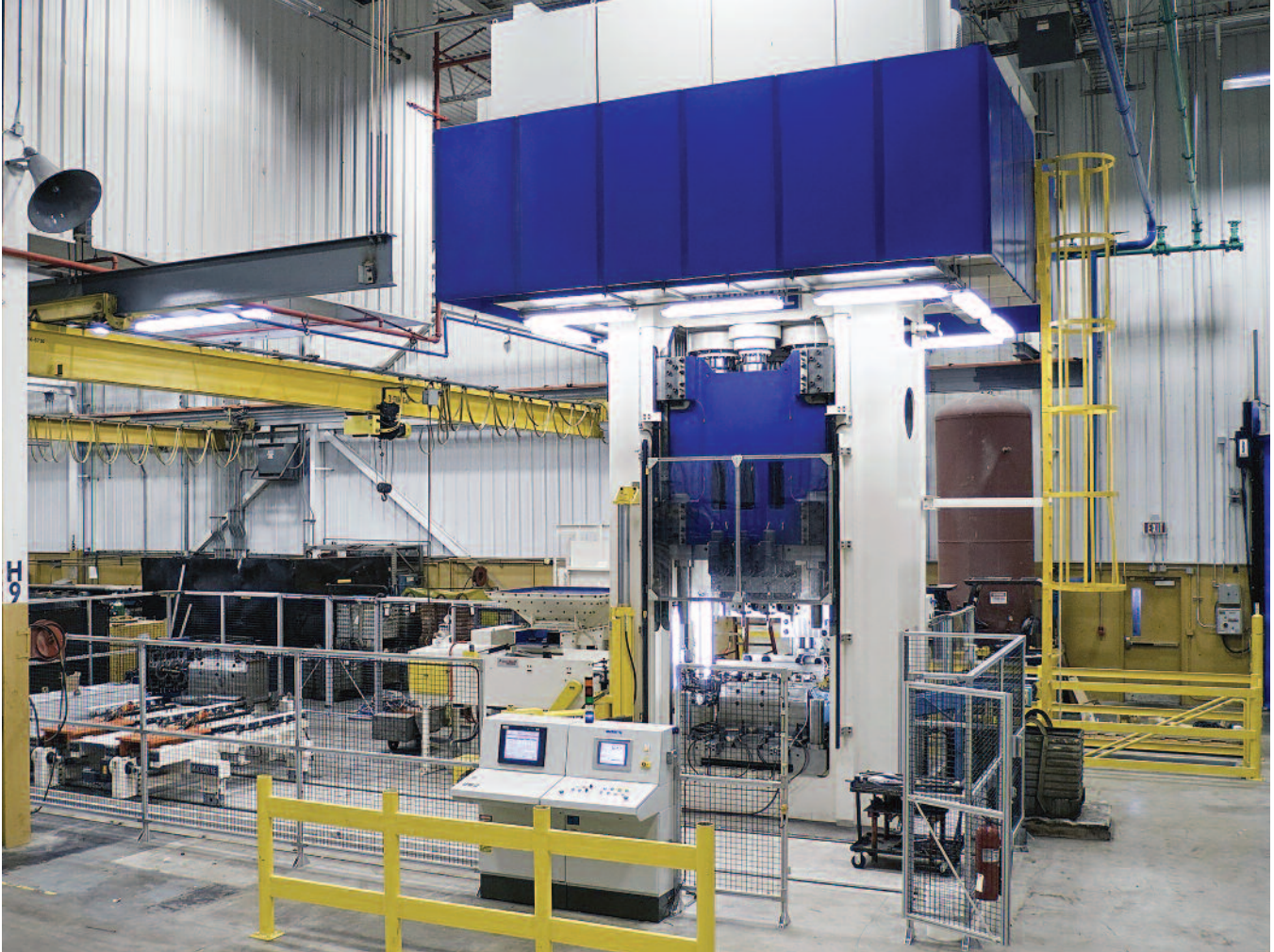

1200 ton cold forming press line complete with hopper feeder, in-press transfer system, and automated die change system

There are many advantages to using Macrodyne hydraulic cold forming presses. Cold formed parts have a high tensile strength as the grain orientation is not interrupted during the forming process. Furthermore, highly complex part geometries can be achieved when our presses are used with advanced cold forming tooling.

Macrodyne hydraulic cold forming presses are custom designed for each specific application, many of which involve multiple forming stations within a single press. By completing multiple separate operations in the same press, production rates are significantly increased and costly secondary operations can be reduced or eliminated entirely.



Two (2) 900 ton cold forming press lines, each comprising a 900 ton press, six (6) strippers and ejectors, 3-station transfer system, part loading robot, and hydraulic tool change arm

Macrodyne hydraulic cold forming presses are available with many features including:

- Heavy duty press frames and slides to accommodate eccentric loading
- Programmable positive stop arrangements for slide stroke limiting
- Closed loop motion controlled ram strippers and die ejectors
- Hopper feeders and part loading/unloading robots
- Automatic grease lubrication systems
- Hydraulic clamping & lifting packages
- Adjustable die wedge assemblies
- In-press transfer systems

EXTRUSION PRESSES



900 ton horizontal extrusion press line

Macrodyne manufactures hydraulic extrusion presses for hot and cold extrusion applications for the production of a wide range of parts produced from a variety of alloys including several grades of steel, aluminum, copper, zirconium, and more.

These presses are typically supplied with monolithic press frame styles and are available in several configurations including down-stroking, up-stroking, and horizontal-stroking.

Our extrusion presses can be supplied as standalone equipment or as part of a turnkey, fully automated extrusion press line similar to that shown above and on the next page.



The above extrusion press line was supplied for the production of copper brazing wire and is comprised of the following:

- 900 ton hydraulic horizontal extrusion press
- Automated billet feeding system
- Integrated induction furnace
- Eight (8) wire winders with adjustable tension set points

COINING PRESSES



2000 ton coining press

Macrodyne supplies hydraulic coining presses for the manufacture of a broad array of precision metal components at production rates up to 60 parts/minute.

Our hydraulic coining presses are equipped with advanced control systems developed through the supply of custom coining press solutions for a multitude of applications, providing precise and repeatable operating characteristics essential to metal coining operations.



1000 ton coining press

Macrodyne coining presses are available with many options including:

- Servo slide position control
- Parallel leveling packages
- Die clamping & lifting packages
- Interface with coil feed systems
- High speed data acquisition systems
- Remote diagnostics packages



500 ton coining press with sliding/tilting table

Macrodyne hydraulic coining presses are equipped with heavy slides that feature a high depth to width ratio. All press structures are analyzed using finite element analysis and are designed to ensure maximum stiffness and torsional rigidity. These structures provide precision guiding, parallel motion, and enhanced eccentric load capabilities.

HYDROFORMING PRESSES



3000 ton sheet hydroforming press

Macrodyne hydroforming presses are designed for both high and low pressure complex hydroforming applications involving sheet or tubular based parts. Our presses are fully integrated with high pressure water systems and associated precise and flexible control systems.

Macrodyne hydroforming presses have a variety of available options including:

- Intensifier units up to 80,000 psi
- Multi-axis feed cylinder assemblies
- Hydraulic auxiliary functions
- Quick die change packages
- Data acquisition packages
- Remote diagnostics packages

Macrodyne hydroforming presses are designed for the manufacture of both solid and hollow components with complex geometries. In many cases, multiple components can be redesigned as a single piece, reducing or eliminating the requirement for secondary welding operations.

Hydroformed parts feature a high level of torsional rigidity in addition to precise dimensional and contour accuracy.

As wall thicknesses are typically thinner than in cast parts, hydroformed parts can be lighter and/or stronger depending on the application requirements.

Our hydroforming presses are used for the production of automotive components, tank manufacturing, plumbing, and a wide variety of industrial product manufacturing applications.

Macrodyne's hydroforming presses can be supplied complete with a wide variety of ancillary equipment including:

- Robots
- In-press transfer systems
- Exit conveyors
- Shuttle tables
- Automated die storage & retrieval systems



1500 ton sheet hydroforming press



HYDROFORMING PRESSES



1400/225/50 ton triple-acting metalforming press with hydroforming package, high speed data acquisition system, and closed loop motion control



2500 ton tube hydroforming press

The above 2500 ton tube hydroforming press with 172" x 84" bed was designed for the manufacture of structural automotive components. The press was supplied with a heavy duty side slab style press frame designed to accommodate heavy eccentric loads, fixed positive stops to prevent over travel, and was integrated with a robot for loading/unloading.



500/4x50 ton tube hydroforming press

The above 500/250/60 ton copper "T" hydroforming press was designed for the high volume production of copper "T" plumbing fittings. The press was supplied complete with an integrated 20,000 psi hydroforming package, slide mounted reaction ram package, two (2) double-acting side cylinders, and two (2) heavy fabricated side bolsters.

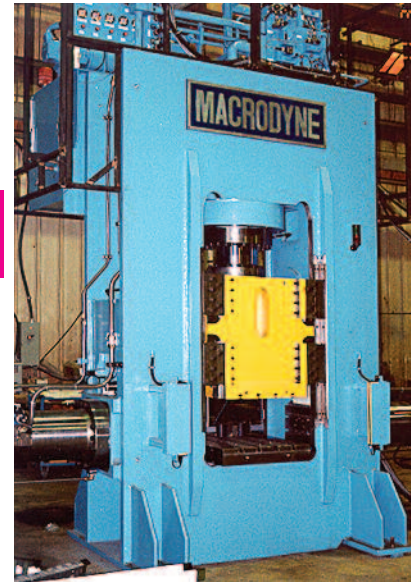

500/250/60 ton copper "T" hydroforming press

The above 500/4 x 50 ton tube hydroforming press was designed for the manufacture of a wide range of kitchen & bath faucets. The press was supplied with a 30,000 psi hydroforming package, six (6) servo proportional controlled end feed cylinders sealing punch arrangement, 2000 psi ejector circuit, and shuttle table arrangement.

DIE SPOTTING & TRYOUT PRESSES



220 ton die spotting press with rolling bolster and 180 degree rotating upper platen

Macrodyne has extensive experience in the supply of hydraulic die spotting & tryout presses. These presses are custom designed for the specific application requirements and are available in a variety of frame styles with many optional features.



250 ton die spotting press with rolling bolster

Macrodyne hydraulic die spotting presses are designed with the functionality, flexibility and precision required for die and mold testing and finishing. We supply both tryout presses and spotting presses for dies and molds for the metalforming and plastics industries.

Our die spotting presses are used to verify the contact surfaces of the upper and lower portions of the die or mold and ensure the dimensional accuracy and precision.

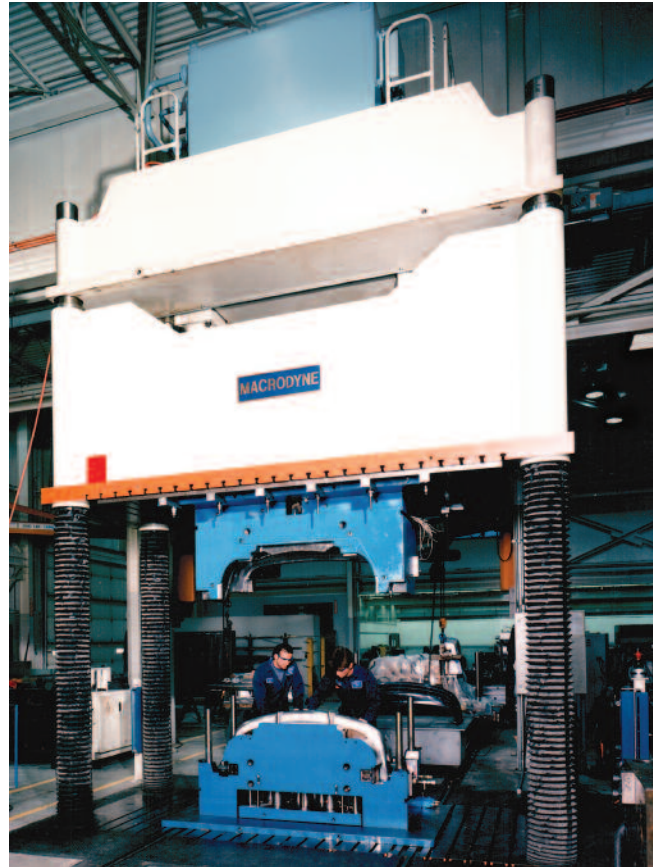

250 ton die spotting press with rolling bolster

Macrodyne die spotting press can be supplied with a variety of features:

- Rolling bolsters
- Tilting platens
- 180 degree rotating platens
- Automatic clamping & lifting packages
- Servo controlled slide parallelism control systems

DIE SPOTTING & TRYOUT PRESSES

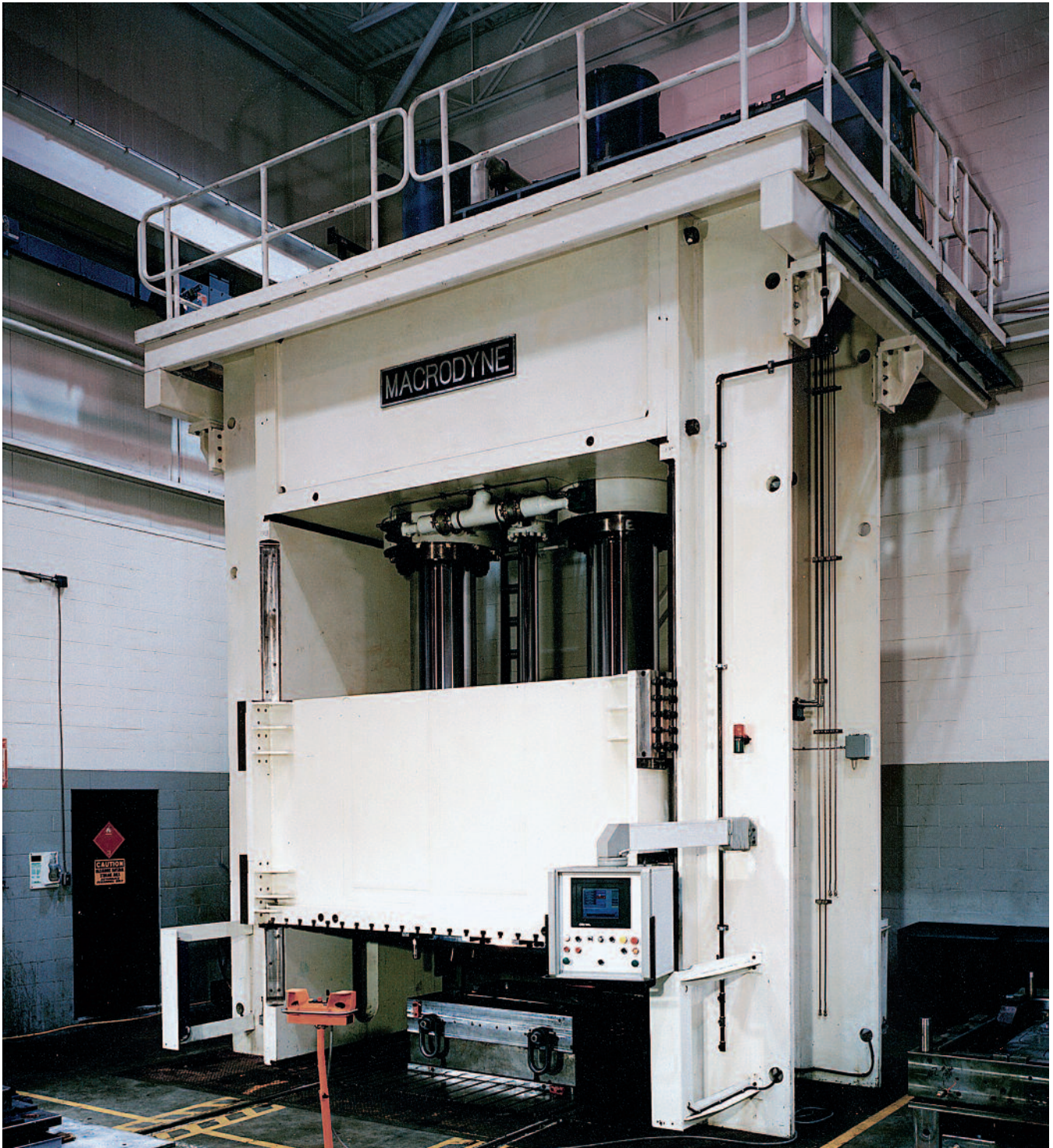

2000 ton tryout press with rolling bolster



220 ton die spotting press with rolling bolster and 180 degree rotating platen

Macrodyne hydraulic tryout presses minimize the die or mold tryout time necessary for pre-production testing of tooling. This enables higher utilization of production presses and ensures faster turnaround times that is particularly critical for short run or just in time production.

Macrodyne hydraulic tryout presses are designed with high flexibility and functionality to offer the ability to optimize the production press operating parameters.



50 ton die spotting press with 90 degree tilting platen and sliding table

Our proprietary tryout press control systems provide the capability to simulate the performance characteristics of production presses, resulting in highly accurate pre-production trials.

These presses feature oversized guiding components and high depth to span ratios for superior platen parallelism. This benefit when coupled with a precision hydraulic and electrical control package ensures precise, repeatable, and reliable operation.

AUTOMOTIVE MOLD & TRIM PRESSES



100/100 ton double-acting molding press

Macrodyne molding presses are available in a variety of configurations: up-stroking, down-stroking or double-acting (one up-stroking platen and one down-stroking platen). These presses are also available with a range of process specific features including heated platens, ejectors, rack & pinion systems for platen parallelism control, and many more.

Our molding presses are used by many of the world's leading manufacturers of automotive interiors to produce an extensive assortment of innovative interior components.



250 ton trim press

The above 250 ton trim press was designed for the trimming of automotive interior components, specifically dashboards for mini-vans. The press features a heavy duty monolithic press frame with operator access on all four sides, two single-acting main cylinders, and one double-acting pull-back cylinder. The press is equipped with a multi-pump based hydraulic drive package, auxiliary circuits for the trim tooling, safety package comprising lock pin arrangement with light curtains and safety gates, and a variety of process specific control features.



Two (2) 120 ton trim presses

The above 120 ton trim presses are part of a tandem press line comprising a lead mechanical press and three Macrodyne hydraulic presses, which are integrated with three robots for loading/unloading and press-to-press transfer. The cell produces completed, stacked, louvered steel panels for a leading manufacturer of residential air conditioners at a cycle rate of 8 seconds. The presses feature a robust 4-column style frame complete with oversized columns, providing improved torsional rigidity, enhanced guiding, and eccentric loading capabilities.



150 ton trim press

The above 150 ton press was specifically designed for a trimming application and is used to trim molded automotive wheel liners. The press features a thermally stress relieved monolithic style frame and deep, heavy, fabricated moving platen. The press is equipped with a multi-pump based hydraulic drive package, two double-acting main cylinders, three proportionally controlled auxiliary circuits for die functions, safety package comprising lock pin arrangement with light curtains and safety gates, and a variety of process specific control features.

AUTOMOTIVE MOLD & TRIM PRESSES



Four (4) 50 ton trim presses

Macrodyne supplies mold and trim presses for a variety of automotive component manufacturing applications. All of our automotive mold and trim presses are custom designed for the Buyer's specific application requirements to ensure an optimal solution for your manufacturing operations.

Our trim presses are available with many useful features such as tilting platens and 180 degree rotating platens. These presses are also used for punching, embossing and other miscellaneous metalforming operations.

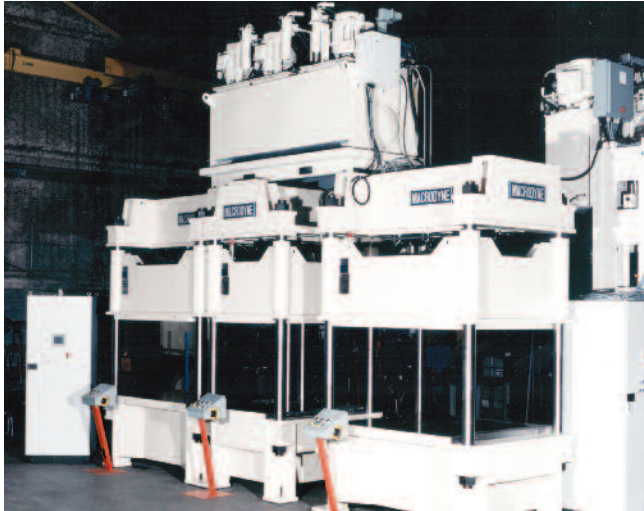

Three (3) 150 ton trim presses with common hydraulics and controls



Four (4) 50 ton trim presses

Macrodyne mold and trim presses are available with a variety of options including:

- Heated platens
- Tilting tables
- 180 degree rotating platens
- Rack & pinion leveling systems
- Rolling bolsters/shuttles
- Vacuum Systems
- Ejectors
- Punches
- Auxiliary circuits for core/eject functions
- Remote diagnostics package

Our mold and trim presses are used in the manufacture of a variety of parts, including:

- Automotive interior panels
- Head liners
- Trunk liners
- Hood liners
- Rear deck liners
- Insulation
- Firewalls
- Foam insulators
- Trimming of sheet metal parts
- Trimming of aluminum castings

SUPER PLASTIC FORMING PRESSES



One (1) 700 ton & three (3) 600 ton super plastic forming presses

Macrodyne manufactures a line of heavy duty, high quality super plastic forming presses. These presses provide the ability to form complex shaped titanium, aluminum and stainless steel components such as engine blades using inert gas forming at high temperatures up to 1800 degrees Fahrenheit.

Macrodyne super plastic forming presses produce a wide array of large precision components that feature a superior surface finish free from residual stresses. Our super plastic forming presses are most commonly used for the production of large components for the aerospace industry.

Our modern super plastic forming presses feature the same high level of quality present in all Macrodyne hydraulic presses and are capable of both super plastic forming and hot forming (hot sizing) operations.

Accurate and repeatable argon gas pressures and multi-zone temperature control are critical elements of a successful super plastic forming operation. These process variables are easily managed using Macrodyne's proprietary flexible and repeatable super plastic forming press control system.

These presses are available in standard configurations or can be customized to suit the Buyer's specific requirements, regardless of the size or complexity.

Standard features of Macrodyne super plastic forming presses include:

- Precise and uniform multi-zone temperature control
- Specialized plunger guide arrangements
- Precision gas management systems
- High-speed data acquisition systems
- Highly efficient heat shields & ceramic insulation
- Heated platens
- Cooling platens
- Rolling bolsters
- Remote diagnostics



175 ton super plastic forming press



700 ton super plastic forming press



400 ton super plastic forming press

ELASTOFORMING PRESSES



7700 ton elastoforming press with shuttle table

Macrodyne elastoforming presses provide the ability to rapidly and cost effectively manufacture high precision sheet metal components for aerospace, automotive, and appliance applications.

Our elastoforming presses are available with the full contingent of features available on all Macrodyne hydraulic presses.

In addition, these presses can be supplied with application specific features including single or dual shuttle tables as well as automated pad change arrangements.

Macrodyne elastoforming presses are typically supplied in monolithic or multi-frame style configurations depending on the forming pad size and specific pressure required over the pad area.

Heavy duty monolithic frames are used for smaller, lower pressure applications. Multi-frames are used for larger, higher pressure applications, and feature the same torsional rigidity of a monolithic frame but with the ability to be disassembled into smaller, lighter components for shipping purposes.



4000 ton elastoforming press with shuttle table

ELASTOFORMING PRESSES



11,000 ton elastoforming press with dual shuttle tables

Macrodyne's modern elastoforming presses feature a high degree of versatility as embossing, bending, and trimming operations can occur simultaneously with an unprecedented degree of accuracy. Furthermore, several different parts can be produced in a single pressing cycle.

Our elastoforming presses produce high strength, high quality parts that require no additional de-burring or finishing and at a much lower cost compared to conventional methods.

Macrodyne elastoforming presses have several unique benefits. Prototyping can be performed rapidly and cost effectively. Tooling costs are low as a small male forming block is typically required, even for complex part geometries.

Using our elastoforming presses also results in lower operating and capital costs compared to traditional fluid cell presses. Combined with faster cycle times, they have become the equipment of choice for many aerospace manufacturers.



2000 ton elastoforming press with shuttle table

HEATED PLATEN PRESSES



1500 ton, 4 daylight, heated platen press with automated loading/unloading systems

Macrodyne supplies a wide range of custom heavy duty single and multiple daylight heated platen presses. Our heated platen presses provide the repeatable and precise performance that offers the uniform pressure distribution required to produce a range of laminates, wood & composite panels, and molded rubber products.



1000 ton, 3 daylight, heated platen press

Macrodyne heated platen presses are available in a variety of frame styles and are most commonly supplied in the multi-frame or monolithic frame style. Depending on the specific application requirements, our heated platen presses can be supplied in up-stroking or down-stroking configurations.

HEATED PLATEN PRESSES

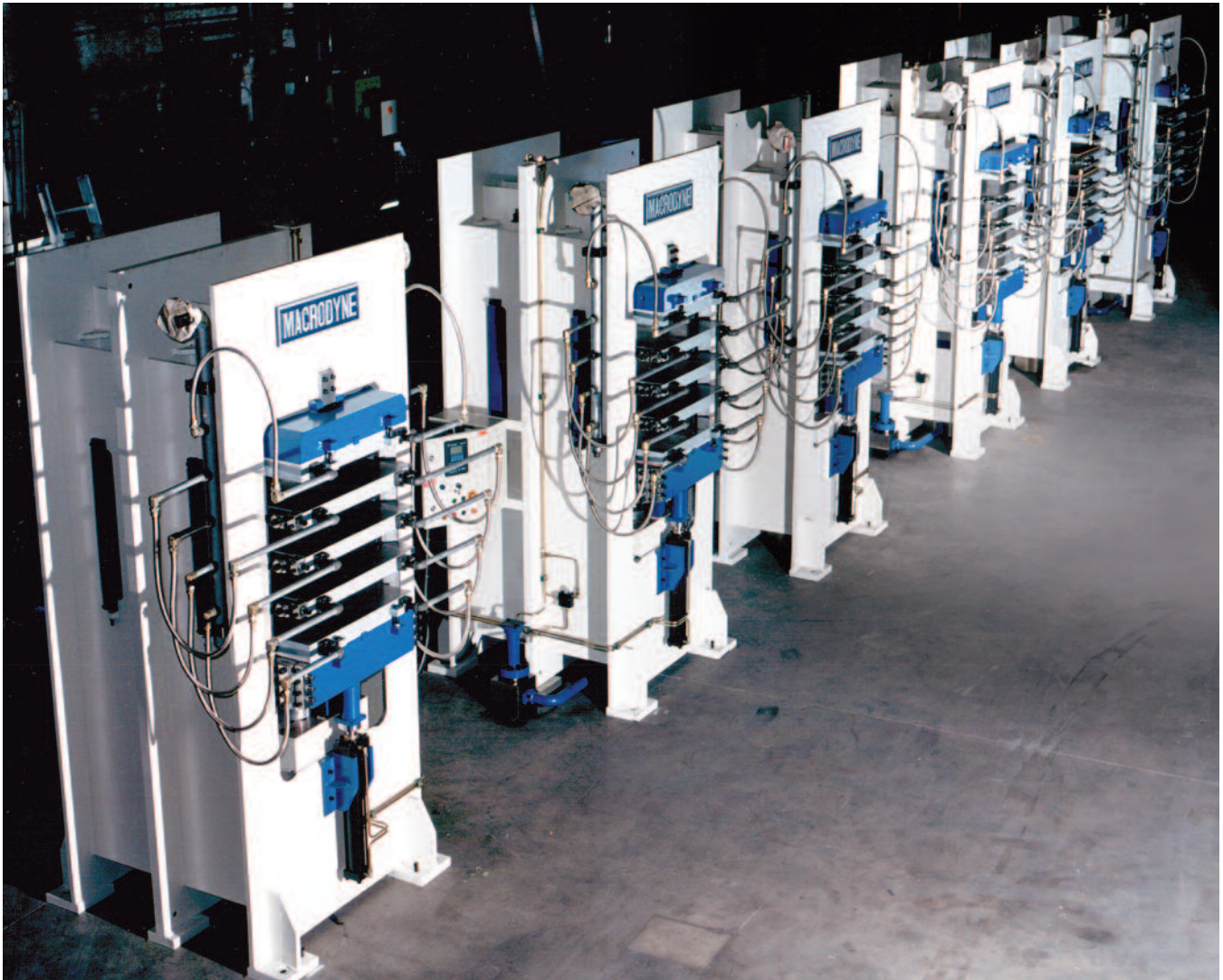

Six (6) 225 ton, 4 daylight, heated platen presses

When supplied with multiple openings (daylights), Macrodyne heated platen presses have the benefit of producing multiple parts during the same pressing cycle as multiple molds can be used in a single press. This is particularly important for processes that require lengthy cure times and can reduce the number of presses required to achieve the desired production output.



7500 ton, 10 daylight, heated platen press with vacuum enclosure and loading/unloading systems

Macrodyne heated platen presses are highly versatile and can be supplied complete with a wide variety of ancillary equipment to further enhance productivity. Available equipment includes heating and cooling systems, press loading and unloading systems, specialized material handling and conveying systems, mold fill systems, process plate transfer systems, and more.

HEATED PLATEN PRESSES

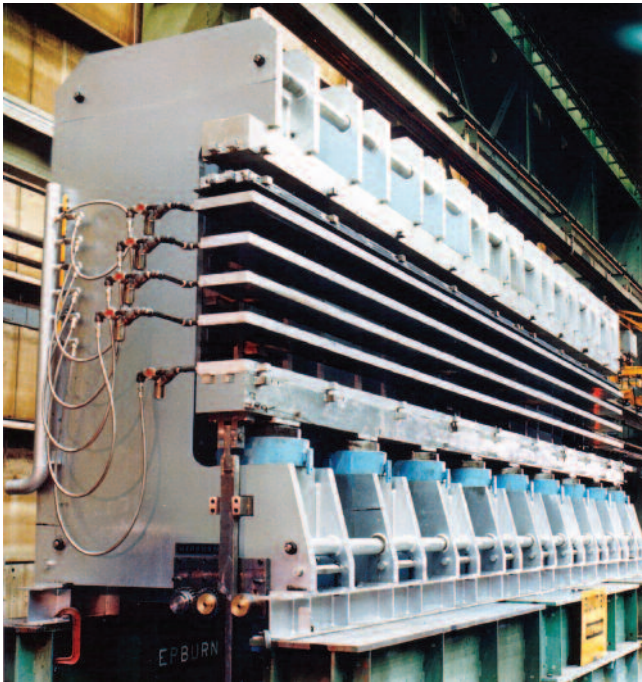

1800 ton, multi-daylight heated platen press

Macrodyne heated platen presses are an optimal choice for many manufacturing processes including:

- Rubber molding
- Wood forming
- Bonding
- UHMW and HDPE
- Decorative laminates
- Industrial laminates
- Advanced composites

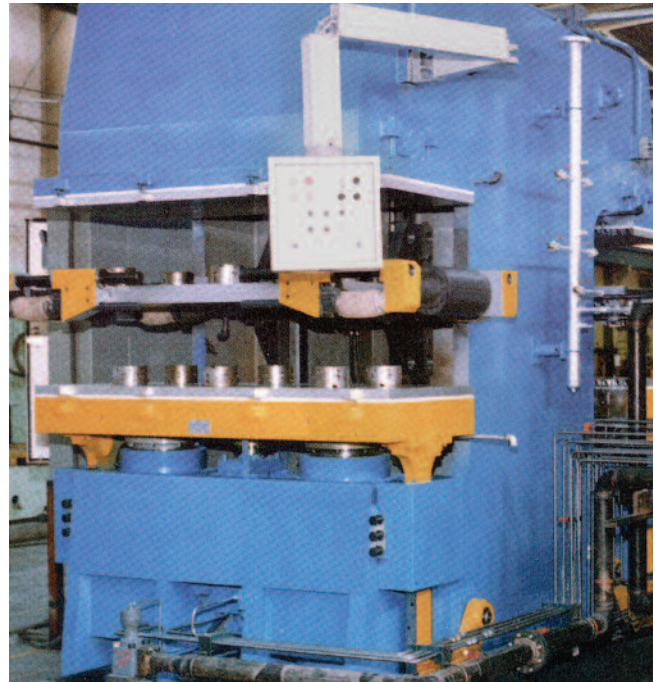

600 ton snowmobile track press

Macrodyne heated platen presses have a variety of available options including:

- Steam, thermal oil or electrically heated platens
- Gas, propane or electrically fired heating systems
- Platen cooling systems
- Vacuum enclosures and systems
- Insulated heat enclosures
- Platen cleaners
- High speed data acquisition systems



1500 ton, 5 daylight, heated platen press

The above Macrodyne 1500 ton press is a hydraulic, up stroking, multiple monolithic frame type that was designed for a concentrically loaded molding application. The press is equipped with two (2) fabricated and thermally stress relieved window style press frames, heated platens, and solid steel moving bottom bolster and fixed solid steel top bolster, both of which were manufactured to prevent distortion.

The press also features $\frac{3}{4}$ " thick insulation panels between the top and bottom bolsters and their respective platens, and two (2) cooling plates mounted between the hydraulic cylinders and the bottom bolster plate to prevent heat from migrating into the bolster plate.



COMPRESSION MOLDING PRESSES



1600 ton SMC compression molding press

Macrodyne is a premier supplier of hydraulic compression molding presses and press lines to the plastics industry. Our compression molding presses are used to produce an extensive variety of innovative automotive, aerospace, industrial, and consumer products.



2000 ton SMC compression molding press



300 ton SMC compression molding presses

Macrodyne compression molding presses are used for a broad range of processes including:

- Sheet molding compound (SMC)
- Bulk molding compound (BMC)
- Multi component molding (MCM)
- Glass mat thermoplastics (GMT)
- Long fiber reinforced thermoplastics (LFRT)
- Low pressure mold compound (LPMC)
- Thermoplastic compression molding
- Transfer molding

A wide variety of features are available for our compression molding presses including:

- Temperature compensated adjustable guiding
- Core/ejector packages
- Platen locking devices
- Mold and platen heating packages
- Direct or accumulator hydraulic drives
- Intelligent platen parallelism packages
- Vacuum packages
- IMC packages

COMPRESSION MOLDING PRESSES

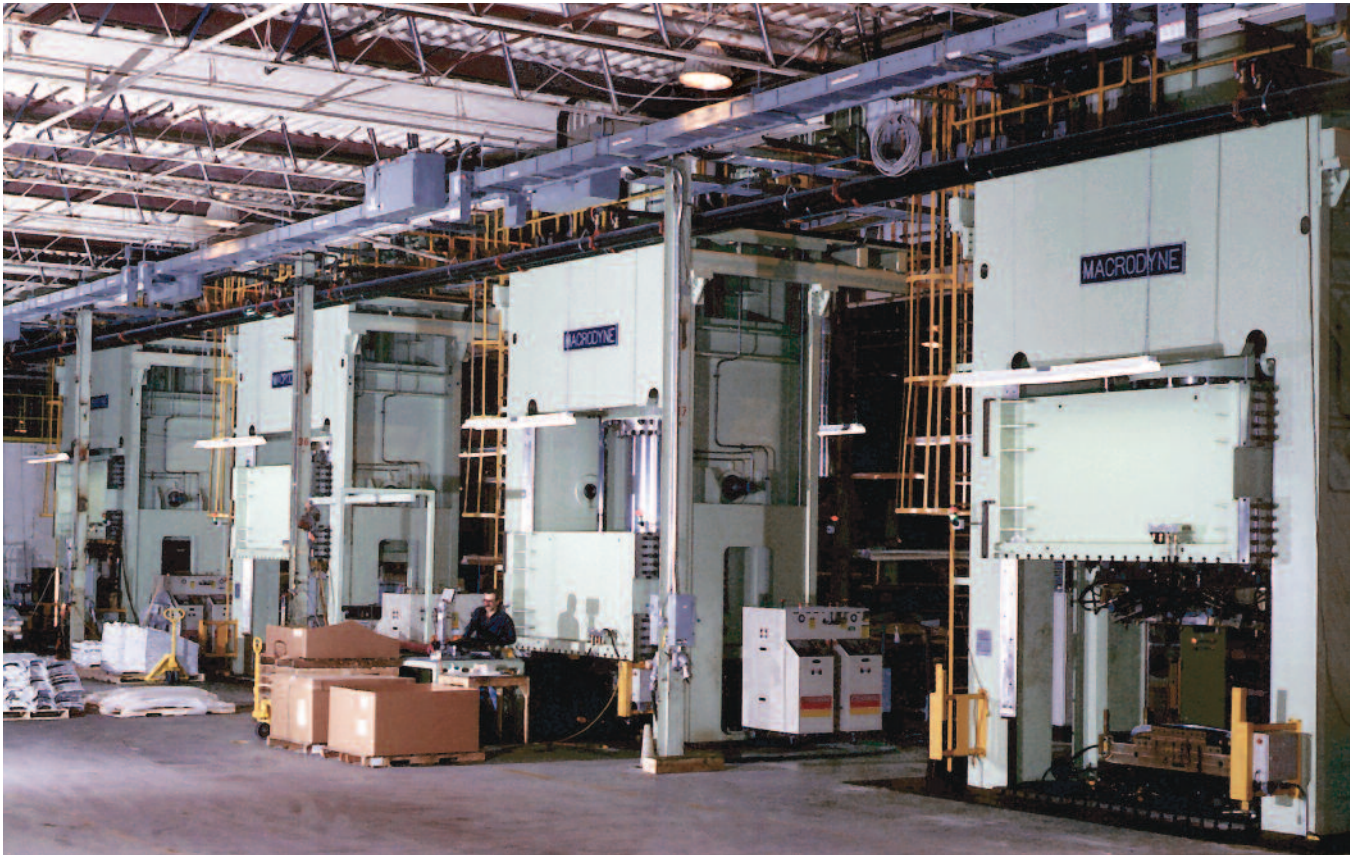

Four (4) 2000 ton SMC compression molding presses

Macrodyne hydraulic compression molding presses are designed for the high volume production of molded components ranging from small, thin precision parts to large, thick parts featuring a myriad of intricate shapes. Fast pressing cycles ensure maximum production output and also prevent buildup of residual stresses in the parts resulting from material viscosity increases during closing of the press.

Precise control of platen motion is a key success factor in compression molding applications. This is readily achieved on our compression molding presses through the use of our proprietary hydraulic circuits and press control systems.

For applications where enhanced platen parallelism is required (such as in-mold coatings), Macrodyne supplies an intelligent parallel leveling package complete with servo-proportional controlled leveling cylinders, powered leveling spindles, and associated electronic control package.

In addition to supplying new custom hydraulic compression molding presses, Macrodyne provides a comprehensive list of repair and upgrade options for existing compression molding presses of all makes and models. Please refer to the press upgrade section of this brochure or visit our website at macrodynepress.com for more information.



Four (4) 2500 ton SMC compression molding presses

The above Macrodyne 2500 ton SMC compression molding presses were supplied for the production of door skins for exterior residential doors. The presses feature heavy duty monolithic frames with 68" x 120" beds and moving platens. Each press is equipped with a multi position pivot & ratchet lock arrangement, vacuum system, core/eject circuits, and an automatic clamping & lifting package. In addition, the presses were supplied with a Macrodyne mold storage & retrieval system to facilitate the rapid and safe loading, unloading, and storage of all molds used in the presses.



Sixteen (16) 100 ton advanced composite molding press lines

The above 100 ton advanced composite molding press lines were specially designed for high volume production of composite insulation for jet engines. Each of the sixteen (16) press lines is equipped with a Macrodyne 100 ton press, 48 kW thermal oil temperature control package, high speed data acquisition system, and electrically interlocked line perimeter safety fencing. Each press features heavy duty chrome plated columns and is equipped with thermal insulation package, die clamping & lifting package, ratio clamp arrangement, and ram block arrangement.

RIM, SRIM & RTM PRESSES

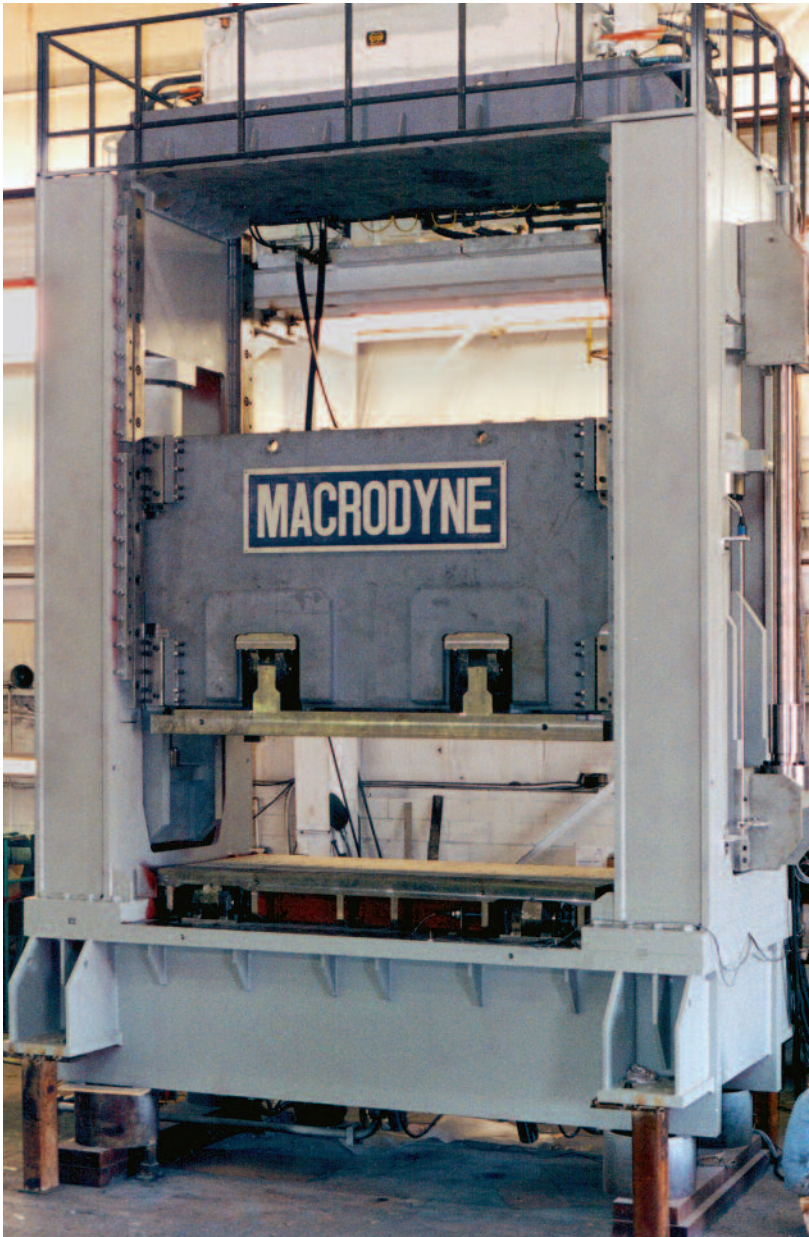

One (1) of three (3) 500 ton RIM clamps

Macrodyne manufactures a line of heavy duty reinforced reaction injection molding (RRIM) clamps, structural reaction injection molding (SRIM) clamps, and resin transfer molding (RTM) clamps for the plastics industry.

Our hydraulic clamps are commonly utilized for the high volume production of automotive and aerospace components. The parts produced are typically lightweight, high strength, and feature a high quality surface finish.

Macrodyne RRIM, SRIM and RTM clamps are available in custom configurations specifically tailored to the customer's application requirements and are available with a wide range of features including:

- Tilting upper and lower platens
- Intelligent parallel leveling systems
- Process specific control systems
- Data acquisition systems

PULP BALING PRESSES

Hydraulic pulp baling presses are specifically designed to ensure consistent and uniform bale size and weight. These presses are available in sizes up to 2500 tons for production rates up to 300 bales per hour. These presses are available in monolithic, 4-column, and housing style frame types to suit your specific application requirements and can be fully integrated with the bale conveyor.

Our pulp baling presses feature process specific, modern PLC based control systems with user friendly touch screen graphic based color displays. The control system features advanced fault diagnostics, full configuration of all machine parameters, operational status, and remote diagnostics. The hydraulic systems feature advanced manifold and logic valve technology incorporating proportional control and efficient direct drive pump/motor groups.

High pressure and kidney loop systems are utilized to provide a high degree of oil filtration to protect hydraulic system components. The hydraulic power units are located on top of the press to simplify service and maintenance while reducing the overall footprint required for installation.



Two (2) 1000 metric ton pulp baling presses

RESEARCH & DEVELOPMENT PRESSES



600/300/150 ton double-acting R&D press with hydraulic cushion

Macrodyne supplies a wide range of hydraulic presses and related automation for many unique research and development applications.

Our hydraulic research & development presses are currently used in some of the world's most advanced academic, government and private sector research facilities.

Macrodyne's research & development presses are used for many advanced processes including:

- Hot gas forming
- Sheet hydroforming
- Tube hydroforming
- Metal formability testing
- Hot stamping
- Warm forming
- Squeeze casting
- Burst testing



The above 600/300/150 ton double-acting research & development press with hydraulic cushion features unprecedented versatility and is capable performing warm forming, gas forming and hot stamping operations in both single and double-acting configurations.

The press is equipped with the following features:

- Integrated heating system for warm forming and warm gas forming
- High speed 3D deformation measuring system/data acquisition system
- 1000 degree Celsius front loading furnace
- Precise, closed loop servo control system
- Ultra low tonnage capability

RESEARCH & DEVELOPMENT PRESSES



900/600/300 ton double-acting R&D press with multi-point blank holder and cushion

Macrodyne research & development presses are designed and manufactured to the same industry leading standards as our production presses, ensuring high quality and long life even in the most demanding research environments.

All of our R&D presses are custom designed for the Buyer's specific research application and can incorporate any desired level of functionality and process automation. Many of our R&D presses are designed for multiple operations, maximizing the research potential available from a single machine or automated cell.

A wide range of optional items are available for these presses including:

- High speed data acquisition systems
- Closed loop motion control on all axes
- Furnaces or ovens
- High speed imaging systems
- Process automation
- Test tools including LDR, Marciniak, bulge test, and more



150/150 ton hot metal gas forming R&D press

The above 150/150 ton double-acting hot metal gas forming R&D press is used for warm gas forming, warm stamping and stamping with in-die quenching and high temperature bulge and dome testing. The press features closed loop control for precise and repetitive control of pressing tonnage, pressing speed and position of both the slide and punch. The press is equipped with an advanced control and data acquisition system, integral 700 degree Celsius furnace, 5000 psi gas management system, metalforming research tooling package and complete press safety package.



1200 ton squeeze casting R&D press

The above 1200 ton R&D press was designed for industrial scale squeeze casting, extrusion, and forging research applications. The press can be easily switched between the various operating modes via separate process selection screens on the operator interface. The press features ultra-low closed loop pressing tonnage, ultra-low closed loop pressing speed and closed loop position control, and monitoring of the slide. The press is equipped with a high speed data acquisition system, die lifting & clamping package, removable bolster extension table, and complete press safety package.



750 ton hydroforming R&D press

The above 750 ton R&D press was designed for advanced hydroforming research applications. This press features servo control of position & speed, and is integrated with Macrodyne's proprietary data acquisition system. The press is equipped with two (2) double-acting end feed cylinder arrangements complete with load cells and tooling adapters, 30,000 psi hydroforming package with 150 cubic inch intensifier volume, primary control console with user-friendly operator interface running on a graphical operating system, and separate user interface computer for data acquisition and servo control functions.

COMPACTION PRESSES



2250/130 ton compaction press for refractory brick

Macrodyne manufactures a line of hydraulic, single or multi-action compaction presses for a variety of applications. These presses feature robust 4-column or monolithic frame construction, and can be designed for the Buyer's exact application requirements to accommodate any specific compaction pressure and fill depth required for optimal production.

Coupled with our advanced control systems, Macrodyne compaction presses are a superior solution for your compaction production requirements.

Macrodyne compaction presses are available with many options including:

- Chargers
- Part load and unload devices
- Mixers
- Robots
- Ejectors
- Weigh feeders



465 ton compaction press for teflon billet production

Macrodyne supplies compaction presses for a variety of applications including:

- Refractory brick
- Metal powder compaction for automotive components
- Magnetic material compaction for automotive, appliance, and medical components
- Tantalum compaction for pharmaceutical and chemical processing applications
- Ceramic compaction for table and sanitary ware
- Ceramic compaction for technical and bio ceramics



The above 2250/130 ton compaction press was specifically designed for a refractory brick application and is equipped with the following features:

- Charger box arrangement including blender assembly
- Moving platen lock arrangement
- Mold table stop arrangement
- CBH ring adapter arrangement
- Hydraulic clamping arrangement
- Automatic grease lubrication package

SPECIAL APPLICATION PRESSES



1400/225/50 ton triple-acting metalforming press with hydroforming package

Macrodyne has extensive experience in the supply of custom hydraulic presses and press lines for virtually every mainstream hydraulic press application.

We also offer a range of custom presses for specialized applications which are specifically designed from start to finish around the requirements of the customer's process and application.

These presses may be supplied alone or in conjunction with ancillary equipment in a press line.



300 ton twin slide press

The above 300 ton twin slide press was specifically designed for a crimping application in the manufacture of insulators for the power generation sector. The press features a heavy duty monolithic press frame designed to accommodate eccentric loading conditions. It is equipped with two (2) independent 150 ton slides, heavy duty guiding arrangement, floor mounted hydraulic drive package, and slide locking arrangement.



600/1500 ton cryofracture press

The above 600/1500 ton cryofracture press was specifically designed to fracture and shear various types of military ordinance containing explosives. The press features a heavy duty press frame capable of withstanding explosive forces and accommodating off-center loading. The press is equipped with blast shield arrangement, discharge chute, shock dampening package, and explosion proof class electrical system.



2500 ton wood molding press

The above 2500 ton press was specifically designed for compression molding of wood components for office furniture. The press features a monolithic frame designed to perform properly under off-center loading conditions and to allow for off-set mold conditions. The press is equipped with a rolling bolster, two (2) hot platens, hot oil distribution package, temperature compensated guide arrangement, and insulation package for the moving platen and rolling bolster.

SPECIAL APPLICATION PRESSES



480 ton, 240 ton, and 40 ton low pressure bonding presses

Macrodyne manufactures hydraulic presses for a wide range of special and custom applications. Examples of some of the presses in these categories include:

- Grinding wheel/abrasive presses
- Bull dozer presses
- Low pressure bonding presses
- Wheel presses
- Rail presses
- Brake pad presses
- Vacuum presses
- Laboratory presses
- Assembly presses
- Multi-slide presses
- Straightening presses

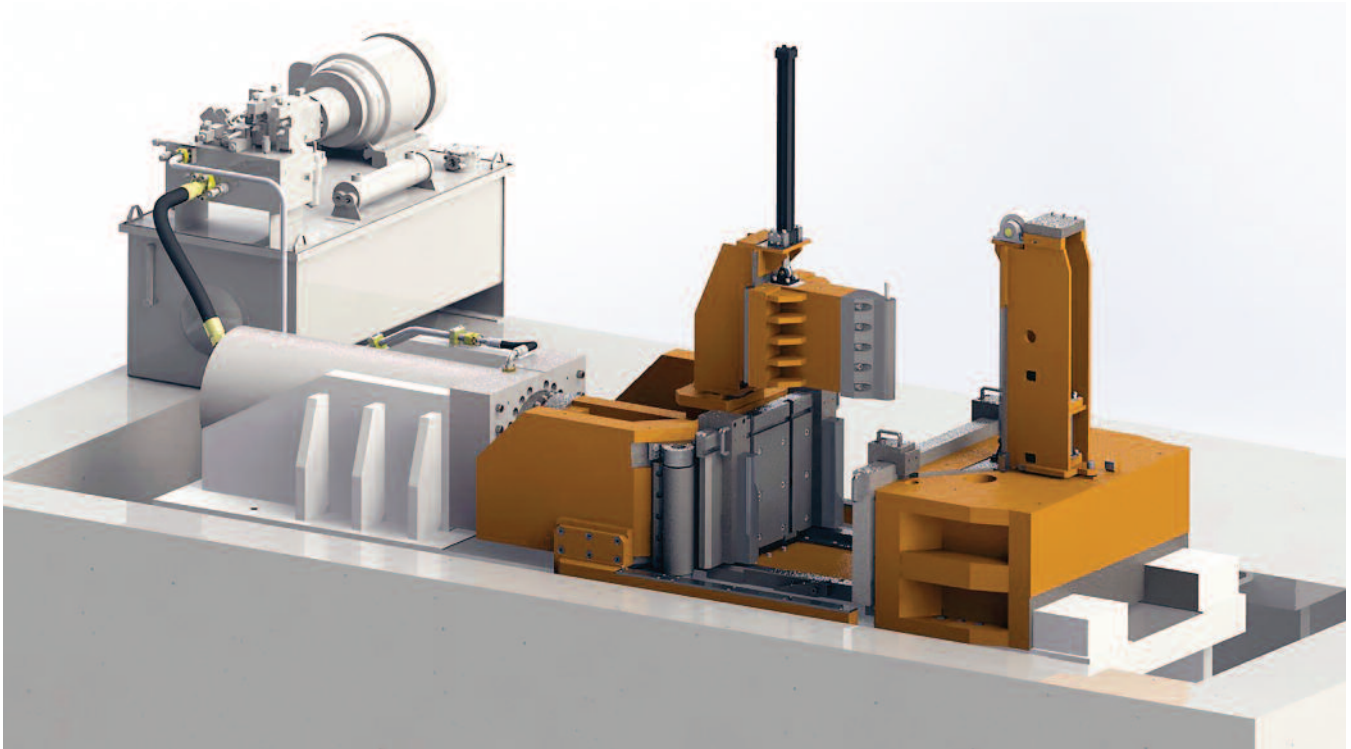

500 ton bulldozer press

The above 500 ton horizontal stroking bulldozer press was designed specifically for a straightening application for heavy forks for forklifts and is equipped with the following:

- Heavy fabricated press frame
- Heavy fabricated fixed rear bolster
- Heavy duty ram guide arrangement
- Heavy fabricated moving ram with fork support bars and fork reverse stop devices
- Hydraulically powered rotating steel bolster plate
- Tooling package including straightening anvils, bull nose anvil, and roller die block

DIE & MOLD HANDLING EQUIPMENT



1200/4x200 ton single acting with cushion draw press served by a Macrodyne die storage & retrieval system

Macrodyne die and mold handling equipment, coupled with quick die change clamping systems, improves the efficiency and productivity of presses or press lines by minimizing the downtime which occurs during die change. This is especially true in light of the demands of just-in-time or short production runs.

Macrodyne supplies a wide variety of die and mold handling equipment to suit virtually any operation and extent of automation. The dies or molds can be exchanged from the systems by overhead cranes, forklifts, or may be stored on racks and retrieved automatically as is possible with an automated die storage

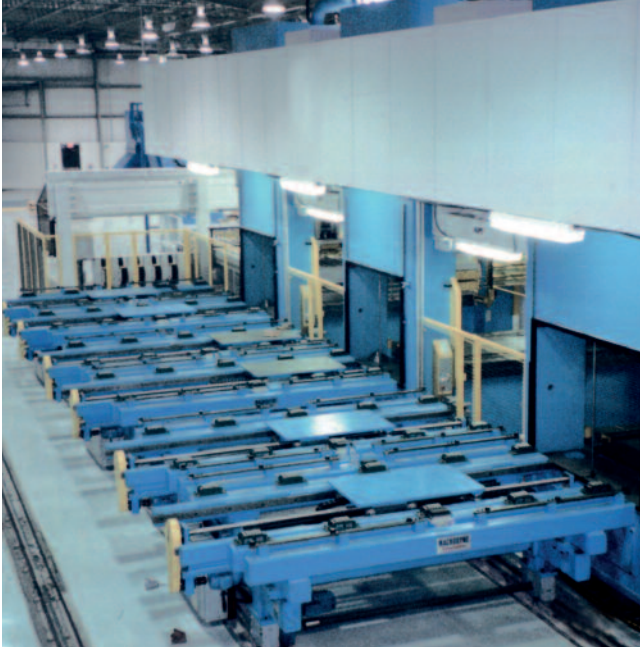

Die storage & retrieval system for forty-two (42) 120" x 72" x 25,000 lb. dies

Macrodyne die and mold handling equipment can be custom designed to integrate with existing presses or may be supplied as ancillary equipment as part of an automated press line with new Macrodyne hydraulic presses.

Macrodyne die and molding handling systems are equipped with comprehensive electrical control packages that provide simple, flexible, user-friendly functionality resulting in rapid and safe die and mold handling.



Die storage & retrieval system serving four (4) Macrodyne 500 ton presses and one (1) Macrodyne 2500 ton hydroforming press

Macrodyne supplies a wide range of die and mold handling equipment including:

- Automated die storage and retrieval systems
- Automated die or mold clamping and lifting packages
- Single or bi-directional die and mold carts
- Die and mold spotting presses
- Rolling bolsters
- Die and mold transfer tables
- Die and mold openers
- Die and mold elevators
- Die and mold storage racks
- Die and mold carrier plates

DIE & MOLD HANDLING EQUIPMENT

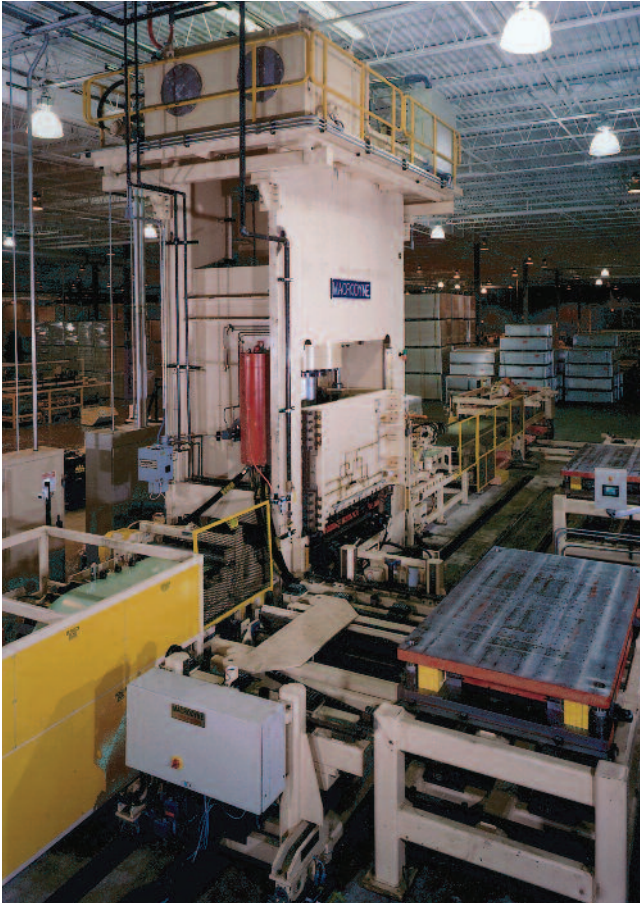

2000 ton hydraulic embossing press, served by a Macrodyne die storage & retrieval system for six (6) 108" x 72" x 20,000 lb. dies

Another major benefit of Macrodyne die and mold handling equipment is the ability to safely and efficiently transport large dies quickly to and from the press or press line for their loading and unloading.

Macrodyne supplies die handling equipment for dies or die sets from several hundred pounds to 100 tons or more. Our die handling equipment is custom designed for your application and can be capable of serving one or more presses in a wide variety of configurations.



Die elevator with twin die load/unload devices

Our automated systems incorporate comprehensive die mold management complete with die mold recognition and die mold registers, flexible storage, pre-staging capability, fault diagnostics, integration with presses or press line monitors, and system and die location monitoring.

Heavy duty racking systems are available to safely store anywhere from several to hundreds of dies. These racking systems are available as a stand-alone item or can be supplied in conjunction with other automated die and mold handling equipment.



Hydraulic press line complete with Macrodyne automated die storage & retrieval system for twenty (20) 30,000 lb dies

The above Macrodyne hydraulic tandem press line was supplied complete with a fully integrated Macrodyne automated die storage & retrieval system. In addition to producing a new part every 6.5 seconds, the system is capable of a complete line changeover (all dies and transfer system tooling) in under 10 minutes. The die storage and retrieval system automatically and rapidly exchanges four (4) 27,000 lb. dies from four (4) presses. The die storage & retrieval system comprises four (4) level die elevator and four (4) level die storage racks with twenty (20) storage positions and eight (8) additional pre-staging die change positions.

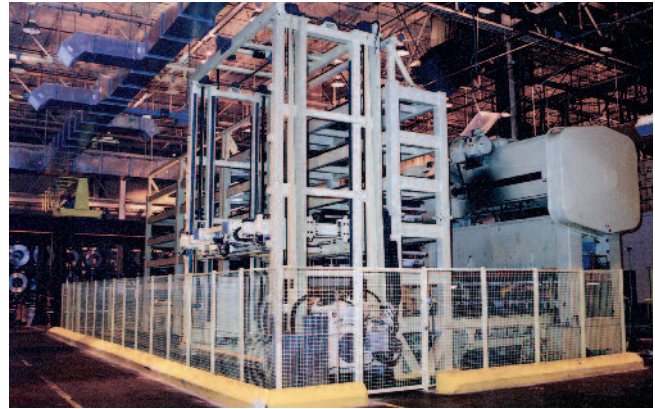

Macrodyne automated die storage & retrieval system for forty (40) 20,000 lb dies, mounted on 95" x 54" die plates

The above Macrodyne automated die storage & retrieval system was designed to automatically store, retrieve and handle forty (40) dies with a maximum weight of 20,000 lbs. This system was supplied to serve two (2) mechanical presses already installed at the Buyer's facility. The die storage & retrieval system comprises multi-level die cart with integral elevator table including die loading/unloading mechanism, seven (7) die storage racks with six (6) stations each, and two (2) die transfer tables. The control system stores location information for each die in the system and the staging positions allow loading and unloading of the presses in five (5) minutes.

ROLLING BOLSTERS & SHUTTLES

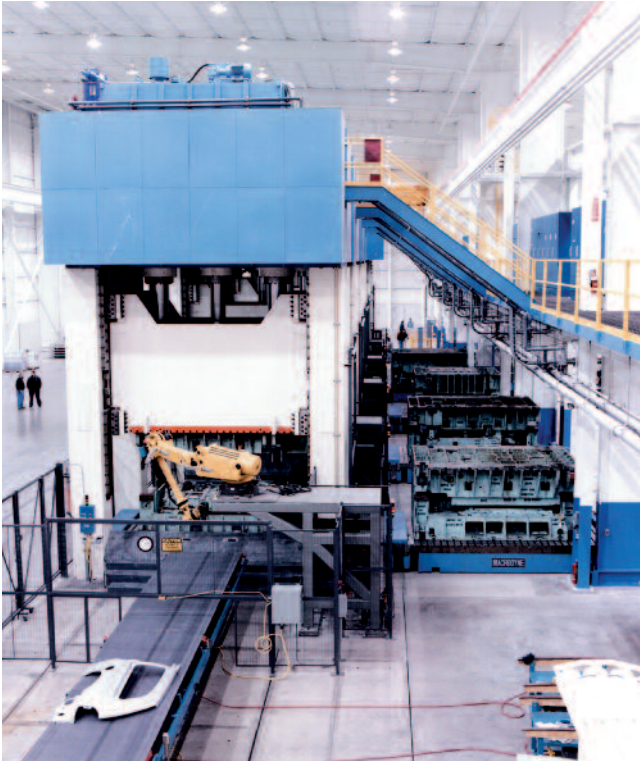

Macrodyne press line with five (5) presses, each supplied with two (2) 180" x 96" "T" type rolling bolsters

Macrodyne hydraulic presses are available with a variety of optional rolling bolsters or die shuttle tables that allow the die to be transferred out of the press for simplified transportation via heavy forklift or overhead crane.

Our rolling bolsters are combined with automatic clamping packages for the upper die half and are integrated with the press control system to facilitate rapid and safe removal of the die or mold from the press.

Using a single rolling bolster, a complete die change can be accomplished within approximately 15 minutes provided that the next die to be used is located in close proximity to the press.



View of "T" type rolling bolsters in pre-staging area

In addition to time savings, the risk of damage to the dies and other equipment due to human error during die changes is eliminated.

To further reduce down time associated with die changes, we offer dual rolling bolster packages. With a dual rolling bolster configuration, the next die to be used in the press can be pre-staged on the second rolling bolster while the press is still operational. When ready for a die change, the bolster in the press exits, and once clear, the second bolster can enter the press allowing for die change in under 5 minutes.



11,000 ton press with dual shuttle tables

User-friendly controls simplify quick die changes. To remove a die from a press equipped with a rolling bolster, the operator simply selects the applicable operation in the press control system and the upper die is automatically unclamped from the slide.

Once disconnected from the slide, the bolster travels out of the press to a safe position where it can be removed by an overhead crane. A new die can then be lowered onto the rolling bolster and the process is automatically repeated in reverse to install the new die in the press.

Once disconnected from the slide, the bolster travels out of the press to a safe position where it can be removed by an overhead crane. A new die can then be lowered onto the rolling bolster and the process is automatically repeated in reverse to install the new die in the press.



1000 ton press with two (2) side to side rolling bolsters

Macrodyne rolling bolsters and die shuttle tables are available in a variety of configurations:

- Front to back rolling bolsters travelling out of the front or rear of the press
- Side to side rolling bolsters travelling out of either side of the press
- “T” type rolling bolsters travelling out of any side(s) of the press
- Single or dual die shuttles connected to any side(s) of the press

PRESS REBUILDS & UPGRADES



Rebuilt 1375 ton metalforming press



Modified 2000 ton press



Rebuilt 750 ton cryofracture press

Macrodyne offers comprehensive press repair, rebuild, and upgrade services for all brands of existing hydraulic presses.

Whether you are interested in upgrading existing presses in your plant or purchasing a used press to modify for your specific application requirements, we have many options available ranging from basic inspection services through complete rebuild & upgrade packages.

Drawing on our extensive hydraulic press design and build expertise developed through the supply of hydraulic presses and press lines for hundreds of unique applications, our multi-disciplinary design team possesses the knowledge and skills required to ensure your press repair, rebuild, or upgrade project is successfully completed in the most efficient and cost effective manner possible.

Macrodyne offers a wide range of hydraulic press rebuild and upgrade services tailored to your specific requirements including:

- Modernization or complete replacement of hydraulic and control systems
- Operating performance enhancements including cycle time improvements
- Press safety upgrades to obtain compliance with applicable safety standards including OSHA, ANSI and CSA Z142.10
- Finite Element Analysis (FEA) and modifications to existing press structures
- Repair or replacement of major press components including frames, platens, housings, tie rods, cylinders, and more
- Programming services to provide additional press functionality
- Inspection and consulting services to assist in used equipment purchase decisions
- Integration of used presses with existing or new ancillary equipment

Macrodyne is a leading manufacturer of:

- Hydraulic Presses
- Hydraulic Press Lines
- Die & Mold Handling Equipment
- Press Loading & Unloading Systems

We also offer a full range of services:

- Press Inspection & Repair Services
- Press Retrofits & Upgrades
- Equipment Relocation Services
- Preventative Maintenance Programs
- Press Line/System Integration Services
- Operation & Maintenance Training Programs



please visit our website or contact us directly at sales@macrodynepress.com or by telephone at (905) 669-2253.

Quality **Innovation** Value

311 Connie Crescent, Concord, ON L4K 5R2
sales@macrodynepress.com 905.669.2253
macrodynepress.com

